

Dale Twachtmann
Secretary

**THE FLORIDA DEVELOPMENT MANUAL:
A GUIDE TO SOUND LAND AND WATER MANAGEMENT**

Prepared by:
Eric Livingston
Ellen McCarron
John Cox
Patricia Sanzone
Nonpoint Source Management Section
Florida Department of Environmental Regulation

The preparation of this report was financed in part through a Water Quality Management Technical Assistance Planning Grant from the United States Environmental Protection Agency under the provisions of Section 208 of the Federal Water Pollution Control Act Amendments of 1972 (Public Law 92-500).

June 1988

Only Chapter 5 and Section 3.10 of Chapter 6 are adopted and incorporated by reference in sections 4.5.2 and 6.1 of "Department of Environmental Protection and Northwest Florida Water Management District Environmental Resource Permit Applicant's Handbook – Volume II (Design Requirements for Stormwater Treatment and Management Systems – Water Quality and Water Quantity)."

[Rule 62-346.091, F.A.C., Effective 11-1-10]

DISCLAIMER

The mention of trade names, commercial products, or specific firms in this Manual is for illustration purposes, and does not constitute endorsement by the Florida Department of Environmental Regulation.

REQUEST FOR INFORMATION

The state of the art in nonpoint source management is still in its infancy and is changing rapidly. The information contained in this manual is based on the best available information at the time of publication. It is the author's intent that the manual, especially the information contained in Chapter 6, will be updated as new information and experience is gained. Recipients and users of the manual are requested to send comments, information or experiences about the various BMPs to the address listed below so that the manual can be updated in the future. Your assistance is appreciated.

Send comments and information to:

Nonpoint Source Management Section
Florida Department of Environmental Regulation
2600 Blair Stone Road
Tallahassee, FL 32399-2400

COST STATEMENT

This public document was promulgated at a cost of \$22,356 or \$20.93 per copy to inform and educate Floridians about the management of nonpoint sources of pollution.

**THE FLORIDA DEVELOPMENT MANUAL:
A GUIDE TO SOUND LAND AND WATER MANAGEMENT**

TABLE OF CONTENTS

<u>Section</u>	<u>Page</u>
<u>CHAPTER 1 INTRODUCTION</u>	
What is Nonpoint Pollution	1-1
Abatement of Nonpoint Source Pollution	1-2
Use of this Manual	1-3
 <u>CHAPTER 2 PRINCIPLES OF SITE PLANNING</u>	
Introduction	2-1
Site Selection and Resource Analysis	2-1
Natural Factors	
Climate	2-3
Geology	2-5
Physiography	2-8
Hydrology	2-14
Soils	2-30
Vegetation and Wildlife	2-35
Cultural Factors	
Land Use	2-45
Traffic and Transit	2-47
Density and Zoning	2-48
Socioeconomic	2-49
Utilities	2-49
Historical and Archaeological Resources	2-50
Aesthetic Factors	
Natural Features	2-51
Spatial Patterns	2-52
Summary	2-52
Appendix 2-1, Major Plant Communities	2-53
Appendix 2-2, Endangered Wildlife	2-55
Appendix 2-3, Endangered Plants	2-62
Appendix 2-4, Soils	2-71

<u>Section</u>	<u>Page</u>
<u>CHAPTER 3 EROSION AND SEDIMENT CONTROL PRINCIPLES</u>	

The Erosion Process	3-1
Types of Erosion	3-1
Factors Influencing Erosion	3-3
Sedimentation	3-10
Sediment Damage	3-10
Hazards Associated with Land Development	3-11
Principles of Erosion and Sediment Control	3-13

CHAPTER 4 PRINCIPLES OF STORMWATER MANAGEMENT

The Stormwater Problem	4-1
What is Stormwater Management	4-3
Florida's Stormwater Problem	4-4
Stormwater Pollutants and Their Removal	4-5
Florida's Stormwater Management Program	4-6
Challenges for the Future	4-7
Principles of Stormwater Management	4-9
Appendix 4-1, Chapter 17-25, Regulation of Stormwater Discharge	4-13
Appendix 4-2, Stormwater Permitting Delegation to the WMDs	4-31

CHAPTER 5 CALCULATIONS TO ESTIMATE RUNOFF

Introduction	5-1
General Procedure	5-1
Rational Method	5-2
Assumptions and Misconceptions	5-2
Limitations	5-4
Components of the Formula	5-5
How to Use	5-12
Appendix 5-1, Calculating Stormwater Treatment Volume	5-33



<u>Section</u>	<u>Page</u>
CHAPTER 6 STORMWATER AND EROSION AND SEDIMENT CONTROL	
<u>BEST MANAGEMENT PRACTICES FOR DEVELOPING AREAS</u>	

Introduction	6-1
Overview of Practices	6-2
Nonstructural Source Controls	6-2
Structural Runoff Controls	6-3
Erosion and Sediment Control Practices	6-5
Guidelines for Using Nonstructural Source Controls	6-9
2.01 - Fertilizer Application Control	6-10
2.02 - Pesticide Use Control	6-14
2.03 - Solid Waste Collection and Disposal	6-28
2.04 - Source Control on Construction Sites	6-36
2.05 - Street Cleaning	6-40
Structural Stormwater Controls	6-47
3.01 - Concrete Grid and Modular Pavement	6-48
3.02 - Detention Basins	6-53
3.03 - Exfiltration Trenches	6-93
3.04 - Grassed Waterways and Swales	6-121
3.05 - Parking Lot Storage	6-164
3.06 - Porous Asphalt Pavement	6-168
3.07 - Retention Basins	6-196
3.08 - Rooftop Runoff Disposal	6-224
3.09 - Storage/Treatment Facilities	6-230
3.10 - Underdrains and Stormwater Filter Systems	6-235
Erosion and Sediment Control Practices	6-301
1.01 - Temporary Gravel Construction Entrance	6-302
1.02 - Construction Road Stabilization	6-305
1.05 - Straw Bale Barrier	6-308
1.06 - Silt Fence	6-315
1.07 - Brush Barrier	6-322
1.08 - Storm Drain Inlet Protection	6-325
1.15 - Temporary Diversion Dike	6-335
1.16 - Temporary Fill Diversion	6-339
1.17 - Temporary Right-of-Way Diversion	6-342
1.18 - Diversion	6-346
1.25 - Temporary Sediment Trap	6-351
1.26 - Temporary Sediment Basin	6-360
Appendix 1.26a - Design Procedure for Temporary Sediment Basin	6-370

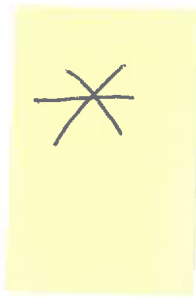

<u>Section</u>	<u>Page</u>
1.30 - Temporary Slope Drain	6-389
1.31 - Paved Flume	6-395
1.35 - Stormwater conveyance Channel	6-401
1.36 - Outlet Protection	6-411
Appendix 1.36a - Sample Problem - Outlet Protection Design	6-418
1.37 - Riprap	6-421
Appendix 1.37a - Riprap Design in Channels	6-428
1.38 - Check Dams	6-435
1.39 - Waterway Drop Structure	6-439
1.40 - Level Spreader	6-445
1.50 - Subsurface Drain	6-449
Appendix 1.50a - Subsurface Drain Design	6-456
1.60 - Surface Roughening	6-463
1.61 - Topsoiling	6-469
1.65 - Temporary Seeding	6-473
1.66 - Permanent Seeding	6-477
1.67 - Sodding	6-492
1.68 - Bermudagrass Establishment	6-501
1.75 - Mulching	6-507
1.80 - Trees, Shrubs, Vines and Ground Covers	6-517
1.85 - Tree Preservation and Protection	6-544
1.86 - Dust Control	6-564

APPENDICES

6-1 - The Design of Multiple Purpose Detention/Filtration Facilities for Water Quantity and Water Quality Management	6-567
6-2 - Discussion of Various Laboratory and Field Testing Procedures for Estimating the Hydraulic Con- ductivity or Coefficient of Permeability (K) of Soils or Filter Sand	6-619
6-3 - Design of Exfiltration Trenches to Meet S.F.W.M.D. Regulatory Criteria	6-637
6-4 - Design Charts for Determining Waterway Capacity	6-664
6-5 - Flow Capacity - Subsurface Drains	6-695

<u>Section</u>	<u>Page</u>
<u>CHAPTER 7 INDIVIDUAL TREATMENT AND DISPOSAL</u>	
Basic Principles	7-1
On-Site Treatment and Disposal Alternatives	7-22
Septic Tanks	7-23
Soil Absorption Systems (Conventional)	7-31
Grease Interceptors	7-43
Alternative Treatment Systems	7-45
Aerobic Treatment Units	7-45
Granular Media Filters	7-53
Fixed Film Systems	7-60
Alternative Disposal Systems	7-65
Mounds	7-65
Evapotranspiration Systems	7-71
Vacuum Sewers	7-75
Pressure Sewers	7-78
Septage Disposal	7-84
On-Site Systems Management	7-85
Water Conservation Methods	7-87
<u>CHAPTER 8 LOCAL GOVERNMENT PROTECTION OF NATURAL RESOURCES</u>	
Introduction	8-1
The Planning Process	
Local Decisionmakers	8-1
The Comprehensive Plan	8-2
The Resource Inventory	8-3
Using the Resource Inventory	8-6
Tolerance and Suitability of Environmental Resources	8-6
Local Planning Implementation	
Regulations	8-15
◦ Ordinances Structure.....	8-15
◦ Resource Protection Ordinance	
Floodplains	8-31
Wetlands	8-34
Shoreline Protection	8-38

<u>Section</u>	<u>Page</u>
° Ordinances for Nonpoint Source Pollution Control	
Stormwater Management	8-41
Onsite Sewage Disposal	8-42
Zoning	8-43
° Planned Unit Developments	8-45
° Subdivision Regulations	8-45
° Land Development Codes	8-46
Transfer of Development Rights	8-47
Public Participation	8-49
Summary	8-50
Appendix 8-A, Model Flood Management Ordinance	8-51
Appendix 8-B, Chapter 40B-4, F. A. C.	8-72
Appendix 8-C, Two Draft Wetland Protection Ordinances	8-96
Appendix 8-D, City of Sanibel Ordinance	8-106
Appendix 8-E, Excerpt from Martin County Comprehensive Plan ...	8-125
Appendix 8-F, Natural River Zoning Ordinance	8-129
Appendix 8-G, Orange County Lakeshore Protection Ordinance	8-161
Appendix 8-H, Franklin County Critical Shoreline Ordinance	8-168
Appendix 8-I, Dade County Severable Use Rights Ordinance	8-179
Appendix 8-J, Collier County Ordinance	8-197

CHAPTER 9 BIBLIOGRAPHY

Citations for 2	9-1
Citations for 3	9-2
Citations for 4	9-2
Citations for 5	9-3
Citations for 6	9-4
Citations for 7	9-15
Citations for 8	9-19

ACKNOWLEDGEMENT

A document of this size, nature and time in the making could not be completed without the assistance and cooperation of many individuals. Financial assistance was provided by a Section 208 grant from the United States Environmental Protection Agency. All past and current staff of the department's Nonpoint Source Management Section contributed to this manual. In particular, the assistance, encouragement and support of Ms. Mimi Drew, Mr. John Ruddell and Ms. Roxane Dow are gratefully acknowledged. A special thank you to Mr. Jim Lewis of the department whose editorial excellence made this document much more readable and understandable.

Members of the Florida Home Builders Association, the Florida Engineering Society and practicing engineers helped to establish the foundation for this document by replying to a questionnaire about the types of management practices used in Florida and sources of design guidelines they used. Consulting engineers, staff from the water management districts and Department of Transportation provided comments on the draft manual that were incorporated into the final document.

Dr. Martin Wanielista and his colleagues at the University of Central Florida Engineering School contributed greatly to the state of the art of stormwater management in Florida, without which much of the information contained in the manual would not exist.

The assistance of the state office of the Soil Conservation Service (James Mitchell - State Conservationist) is greatly appreciated, especially the review and modifications to the erosion and sediment control practices to make them Florida specific. This was done by Mr. Robert Johnson, Mr. Bob Craig and Mr. Robert Groce.

Our sincere appreciation is extended to Mr. Gerald Sealey, Jr. and Mr. Scott Crafton of the Virginia Soil and Water Conservation Commission and to the Commission for allowing many parts of the Virginia Erosion and Sediment Control Handbook to be used verbatim in this manual.

Figure 2-1 is from Earthscape by John Simonds and is used with the permission of McGraw-Hill Book Company. Figure 2-8 is from A Guide to Site and Environmental Planning by Harvey Rubenstein and is used with the permission of John Wiley and Sons Publisher. Ms. Sylvia Worth prepared several of the original figures and assisted with other graphic needs.

We wish to thank Ms. Tish Elliot, Ms. Alisa Gregory and Ms. JoAnne Cranley for their excellent word processing work on the draft document which was submitted to the EPA in September 1984. A special thank you to Ms. Sue Sullivan, the section's current secretary, who not only typed most of the final document, but also provided needed encouragement and skillful assistance to staff and maintained her cheerful disposition throughout the project. Ms. Lauren Suber also contributed to typing of the final document.

Chapter 6

Stormwater and Erosion and Sediment Control Best Management Practices for Developing Areas

This chapter contains a comprehensive summary of BMPs used for stormwater management and erosion and sediment control. Part 1 discusses various non-structural source controls that can be used to reduce the generation and accumulation of potential stormwater contaminants. Part 2 discusses structural stormwater BMPs that can be used to reduce the pollutant load discharged from stormwater systems. Part 3 discusses erosion and sediment control BMPs that can be used to reduce erosion and retain sediment on-site, especially during construction.

The BMP guidelines represent a summary of the best available information at the time of publication. However, the state-of-the-art is still quite young and these guidelines will probably change as new research is completed and as we gain more experience with using the various BMPs. Design engineers and others in the development community are encouraged to send the department information about actual experiences with the BMPs so that the guidelines can be periodically updated.

The erosion and sediment control BMP descriptions have been largely taken verbatim from the Virginia Erosion and Sediment Control Manual although the information was "Florida-ized" by the Soil Conservation Service and others. These BMP descriptions are written in the form of mandatory standard and specifications because of Virginia's Erosion and Sediment Control Act. It is not the intention of the department to require strict compliance with these standards although they do represent excellent guidelines based on years of actual implementation.

Engineers are encouraged to use the information presented in this chapter in conjunction with their own expertise to assure that the BMPs will be properly designed and constructed for their particular site and situation.

Section 3.10
only

CHAPTER 6

STORMWATER AND EROSION AND SEDIMENT CONTROL BEST MANAGEMENT PRACTICES FOR DEVELOPING AREAS

TABLE OF CONTENTS

<u>Section</u>	<u>Page</u>
INTRODUCTION	6-1
OVERVIEW OF PRACTICES	6-2
Nonstructural Source Controls	6-2
Structural Runoff Controls	6-3
Erosion and Sediment Control Practices	6-5
GUIDELINES FOR USING NONSTRUCTURAL SOURCE CONTROLS	6-9
2.01 - Fertilizer Application Control	6-10
2.02 - Pesticide Use Control	6-14
2.03 - Solid Waste Collection and Disposal	6-28
2.04 - Source Control on Construction Sites	6-36
2.05 - Street Cleaning	6-40
STRUCTURAL STORMWATER CONTROLS	6-47
3.01 - Concrete Grid and Modular Pavement	6-48
3.02 - Detention Basins	6-53
3.03 - Exfiltration Trenches	6-93
3.04 - Grassed Waterways and Swales	6-121
3.05 - Parking Lot Storage	6-164
3.06 - Porous Asphalt Pavement	6-168
3.07 - Retention Basins	6-196
3.08 - Rooftop Runoff Disposal	6-224
3.09 - Storage/Treatment Facilities	6-230
3.10 - Underdrains and Stormwater Filter Systems	6-235
EROSION AND SEDIMENT CONTROL PRACTICES	6-301
1.01 - Temporary Gravel Construction Entrance	6-302
1.02 - Construction Road Stabilization	6-305
1.05 - Straw Bale Barrier	6-308
1.06 - Silt Fence	6-315
1.07 - Brush Barrier	6-322
1.08 - Storm Drain Inlet Protection	6-325
1.15 - Temporary Diversion Dike	6-335
1.16 - Temporary Fill Diversion	6-339
1.17 - Temporary Right-of-Way Diversion	6-342
1.18 - Diversion	6-346
1.25 - Temporary Sediment Trap	6-351
1.26 - Temporary Sediment Basin	6-360
Appendix 1.26a - Design Procedure for Temporary Sediment Basin	6-370
1.30 - Temporary Slope Drain	6-389



CHAPTER 6

STORMWATER AND EROSION AND SEDIMENT CONTROL BEST MANAGEMENT PRACTICES FOR DEVELOPING AREAS

TABLE OF CONTENTS (CONTINUED)

<u>Section</u>	<u>Page</u>
EROSION AND SEDIMENT CONTROL PRACTICES (Continued)	
1.31 - Paved Flume	6-395
1.35 - Stormwater conveyance Channel	6-401
1.36 - Outlet Protection	6-411
Appendix 1.36a - Sample Problem - Outlet Protection Design	6-418
1.37 - Riprap	6-421
Appendix 1.37a - Riprap Design in Channels	6-428
1.38 - Check Dams	6-435
1.39 - Waterway Drop Structure	6-439
1.40 - Level Spreader	6-445
1.50 - Subsurface Drain	6-449
Appendix 1.50a - Subsurface Drain Design	6-456
1.60 - Surface Roughening	6-463
1.61 - Topsoiling	6-469
1.65 - Temporary Seeding	6-473
1.66 - Permanent Seeding	6-477
1.67 - Sodding	6-492
1.68 - Bermudagrass Establishment	6-501
1.75 - Mulching	6-507
1.80 - Trees, Shrubs, Vines and Ground Covers	6-517
1.85 - Tree Preservation and Protection	6-544
1.86 - Dust Control	6-564
APPENDICES	
6-1 - The Design of Multiple Purpose Detention/Filtration Facilities for Water Quantity and Water Quality Management	6-567
6-2 - Discussion of Various Laboratory and Field Testing Procedures for Estimating the Hydraulic Con- ductivity or Coefficient of Permeability (K) of Soils or Filter Sand	6-619
6-3 - Design of Exfiltration Trenches to Meet S.F.W.M.D. Regulatory Criteria	6-637
6-4 - Design Charts for Determining Waterway Capacity	6-664
6-5 - Flow Capacity - Subsurface Drains	6-695

SW BMP 3.10

UNDERDRAINS AND STORMWATER FILTRATION SYSTEMS

Definition

Stormwater underdrain and filtration systems usually consists of a conduit, such as a pipe and/or a gravel filled trench, which intercepts, collects, and conveys stormwater following infiltration and percolation through the soil, suitable aggregate, and/or filter fabric. Many of the principles established for "subsurface drains" discussed earlier in the chapter may also apply.

Purpose

In Florida, these systems serve one or more of the following purposes:

- 1) To filter a portion (normally 0.5 to 1-inch) of the stormwater runoff contained in detention facilities prior to discharge to surface waters or other receiving waters of the state.
- 2) To alter the soil environment in treatment areas when not suitable for desired vegetation; usually by regulating the period of inundation, the water table elevation, and/or the inflow of shallow groundwater.
- 3) To improve the infiltration and percolation characteristics of the soil in stormwater management facilities when permeability is restricted due to soil texture or high water table conditions.



Conditions Where Practice Applies

Underdrain systems and filters are used in combination with a variety of storm-water management measures where space, soil permeability, and/or water table conditions dictate that sufficient pollutant removal cannot normally be achieved through natural percolation, sedimentation, or other means. A gravity outlet must be available or pumping must be provided. A pumped discharge will usually require a permit from the Department and/or Water Management District.

Planning Considerations

Underdrains and filter systems are very similar in design. They differ slightly in their function however.

An underdrain system is intended to improve the percolation rate of the soil and/or control the water table elevation over the entire area of a stormwater treatment facility. Examples include the installation of a tile drainage system in the bottom and along the banks of a detention pond, in the bottom of a grassed waterway, or under a site used for overland flow or landspreading of stormwater. Such a system would be needed when the soil has a good capacity for percolation but has high water table conditions that otherwise prevent the infiltration of the prescribed amount of stormwater through the soil profile of the treatment facility.

A filtration system may also function to lower the water table in its immediate vicinity to some extent; however, the system is not usually designed with this in mind. Filters are normally installed in the bottom or along the banks of detention ponds above the water table elevation. The trench or bed where conduits are installed represent only a small part of the area of the storage facility. The trench is usually backfilled to the surface with aggregate material that is much more permeable than the surrounding soil. Pollutant removal primarily occurs as the prescribed volume of stormwater passes through the sand, gravel, and filter cloth which usually surrounds the conduit.

Filter systems may be used in situations where underdrains are not suitable. For example, filtration is often used in combination with wet detention facilities. Likewise, filtration may be used in situations where the natural soil permeability is restrictive to percolation even when underdrained due to a high percentage of clay or other fine material.

The selection of suitable filter material is critical to the pollutant removal capacity of filter systems. When selecting backfill material the designer should consider its pollution abatement capability not just its hydraulic efficiency. Research has shown that a high percentage of the pollutants associated with urban stormwater may be absorbed on the fine and very fine solids portion of the sediment carried by runoff waters. Generally the more porous and highly permeable the filter fill material, the less efficient the system will be in removing many stormwater contaminants.

In most cases percolation through the soil profile will provide better pollutant removal rates than filter material. However, in some poorly graded, very sandy soils, or in areas where facilities are excavated into highly porous limestone formations, a filter may be capable of providing more treatment than the natural base material. In these circumstances, detention ponds should be lined with impermeable material and the first one-half to one-inch of runoff filtered before discharge to surface water or percolation to groundwater.

Design Criteria

The design of underdrains and stormwater filtration systems involves several steps. The procedures are illustrated below through the use of several example situations.

PART-I

Conventional Underdrain System Design Using Spacing Equations (Normally Used in Conjunction with Dry Detention Facilities)

Suppose the designer has a project in which the area contributing runoff is a 10-acre office complex. Six acres are impervious and 4 acres are lawn. Based on the initial site survey and published soil survey information, the permeability (e.g., hydraulic conductivity) of the soil is estimated to be 10.0 inches per hour. The site has slow internal drainage due a restrictive layer of finer textured materials which occurs at approximately 80 inches below the surface. The slope of the project averages 0 to 2%. The soils are classified as sandy.

The task of the engineer is to determine the length of underdrain required to drain and filter the water from a detention pond within 72 hours as specified by state regulations. Assume the facility was designed to store the runoff from the first inch of rainfall prior to any direct discharge to surface waters. No additional local water quantity regulations have been adopted. The designer would like the holding area to be no more than 3 feet deep. The steps in sizing an underdrain system to satisfy the provisions discussed above are:

1) Calculate Storage Volume and Area of the Facility

Due to the small size of the project the detention volume (e.g. the amount of runoff to be temporarily stored for filtration through the soil and/or underdrain system) can be most appropriately estimated using a modified form of the Rational Formula.

Volume of Rainfall Excess (Runoff) = CAR
where: C = Runoff or Rational Coefficient
A = Contributory Area in Acres
R = Rainfall

Converting the volume of runoff to cubic feet we find:
Runoff = C (A acres) (R inches) $\frac{1 \text{ ft}}{12 \text{ in}}$ (43,560 ft²/Ac) or,

$$\text{Runoff} = \text{CAR} (3,630) \text{ft}^3$$

The contributory area (A) is 10 acres and the amount of rainfall (R) with which we are concerned is equal to one inch. However, the runoff coefficient (C) must be established in order to calculate the volume to be treated.

Runoff coefficients have been estimated for various land uses with some typical values shown in Table 6-12. The selection of the appropriate value is at the discretion of the designer and should be based upon experience. Designers generally use average values for pollution control and larger, more conservative values when sizing flood abatement structures.

In this instance the project will be composed of 4 acres of lawns and 6 acres impervious area with flat (0 - 2%) slopes and sandy soil. The procedure used to determine the average value of (C) for this project is illustrated in Table 6-13. The preparation of such a table is useful to the designer to help explain the basis for the coefficient used in runoff calculations. Such foresight may speed up approval from officials responsible for reviewing design plans to determine compliance with various water management regulations.

Substituting C = 0.60 into the equation:
Runoff = CAR (3,630 ft³) = (0.60) (10) (1) (3,630) ft³; or, 21,780 ft³.

Therefore, in order to satisfy the requirements of the example problem the detention area must be capable of detaining and filtering approximately 21,800 ft³ of runoff prior to discharge.

Since the holding area is being designed for a maximum depth of 3 feet, it will average approximately 7260 ft² in area (21,780 ft³ volume divided by the 3 ft depth of the facility).

2) Determine Drain Spacing

The area over which a subsurface drain can be expected to function must first be estimated in order to determine the length of underdrain needed to lower the water level in the holding area to the desired elevation within a specified time interval. In humid areas such as Florida, both the depth and spacing of drains have been determined largely by experience and judgement

TABLE 6-12
Runoff Coefficients^{a, b}

DESCRIPTION OF AREA	RUNOFF COEFFICIENTS	CHARACTER OF SURFACE	RUNOFF COEFFICIENTS
Business		Pavement	
Downtown	0.70 to 0.95	Asphalt or concrete	0.70 to 0.95
Neighborhood	0.50 to 0.70	Brick	0.70 to 0.85
Residential		Roofs	0.70 to 0.95
Single Family	0.30 to 0.50	Lawns, Sandy Soil	
Multiunits, detached	0.40 to 0.60	Flat, 0-2%	0.05 to 0.10
Multiunits, attached	0.60 to 0.75	Average, 2-7%	0.10 to 0.15
Residential, suburban	0.25 to 0.40	Steep, 7% or more	0.15 to 0.20
Apartment	0.50 to 0.70	Lawns, Heavy Soil	
Industrial		Flat, 2%	0.13 to 0.17
Light	0.50 to 0.80	Average, 2-7%	0.18 to 0.22
Heavy	0.60 to 0.90	Steep, 7% or more	0.25 to 0.35
Parks, Cemeteries	0.10 to 0.25		
Railroad Yard	0.20 to 0.35		
Unimproved	0.10 to 0.30		

^aThe coefficients in these two tabulations are only applicable for storms of 5 to 10 year return frequencies and were originally developed when many streets were uncurbed and drainage was conveyed in roadside swales.

For recurrence intervals longer than 10 years, the indicated runoff coefficients should be increased, assuming that nearly all of the rainfall in excess of that expected from the 10 year recurrence interval rainfall will become runoff and should be accommodated by an increased runoff coefficient.

The runoff coefficients indicated for different soil conditions reflect runoff behavior shortly after initial construction. With the passage of time, the runoff behavior of sandy soil areas will tend to approach that of heavy soil areas. If the designer's interest is long term, the reduced response indicated for sandy soil areas should be disregarded.

^bFrom Design and Construction of Sanitary and Storm Sewers. ACSE Manual of Practice No. 37, 1970. Revised by D. Earl Jones, Jr.

Wanielista M.P. et.al. "Stormwater Management Manual", 1981

TABLE 6-13

Example Procedure for Determination of
Average Runoff Coefficient (C)

Acreage	Land Use	Values of C (Min) (Max) Table 1	Value of C Selected	Acreage x C Selected
4 Ac	Lawns (Sandy Soil, Flat Slope 0-2%)	0.05 to 0.10	0.075	0.30
<u>6 Ac</u>	Roofs, Asphalt, or Concrete	0.70 to 0.95	0.95	<u>5.70</u>
Total 10 Ac				Total 6.00

$$\text{Avg. C} = \frac{\text{Total from Column 5}}{\text{Total from Column 1}}$$

$C = \frac{6.00}{10} = .60$

for specific soil conditions. Optimum drain spacing for laterals is influenced by soil permeability, drain depth, optimum depth of water table desired after drainage, cover crops, depth to impervious strata, and the outlet elevation of the system. The minimum cover over the drain should be 2 feet in mineral soils and 2.5 feet in organic soils. The drain trench depth usually varies from 30 to 60 inches. Where practical, increasing the depth of the drain will permit the use of wider spacing and minimize the length of underdrain required for the facility.

In areas where drainage installations and knowledge of effective spacings are limited, the ellipse equation or other similar procedures may be used to determine underdrain spacing. As noted earlier, the procedures used to design the underdrain systems presented in this manual are largely based on techniques commonly used to design agricultural subsurface drainage systems by the Soil Conservation Service (SCS).

The "Ellipse Equation" is expressed as:

$$S = \sqrt{\frac{4K(m^2 + 2am)}{q}}$$

Where:

S = drain spacing (feet)

K = average hydraulic conductivity (in./hr.)

m = vertical distance, after drawdown, of water table above drain at midpoint between lines (feet)

a = depth of barrier below drain (feet)

q = drainage coefficient (in./hr.)

d = depth of drain (feet)

c = depth to water table desired (feet)

(refer to Figure 6-38)

NOTE: The units of K and q may be in "inches removed in 24 hours" or "gallons per square foot per day" but both must be in the same units in this equation. Where there is no barrier stratum present, a barrier should be assumed at a depth equal to twice the drain depth.

Underdrains are designed to remove a certain quantity of groundwater from a given area subject to a high water table due to poor internal drainage. They are used where lateral groundwater flow or movement toward the treatment area is expected to be insignificant. The quantity of water to be removed by the drain is equal to the storage volume which must be percolated within that given area. The objective of the system is to remove a quantity of water that will lower the water table to some predetermined level during the required period of time. The design is based on the spacing and depth required to maintain a certain minimum water level at the midpoint between drains. This is illustrated in Figure 6-38 which shows the configuration of the new water table established after drainage.

FIGURE 6-38

Cross-Section of Detention Facility with Underdrain System Illustrating Symbols Used in the Ellipse Equation

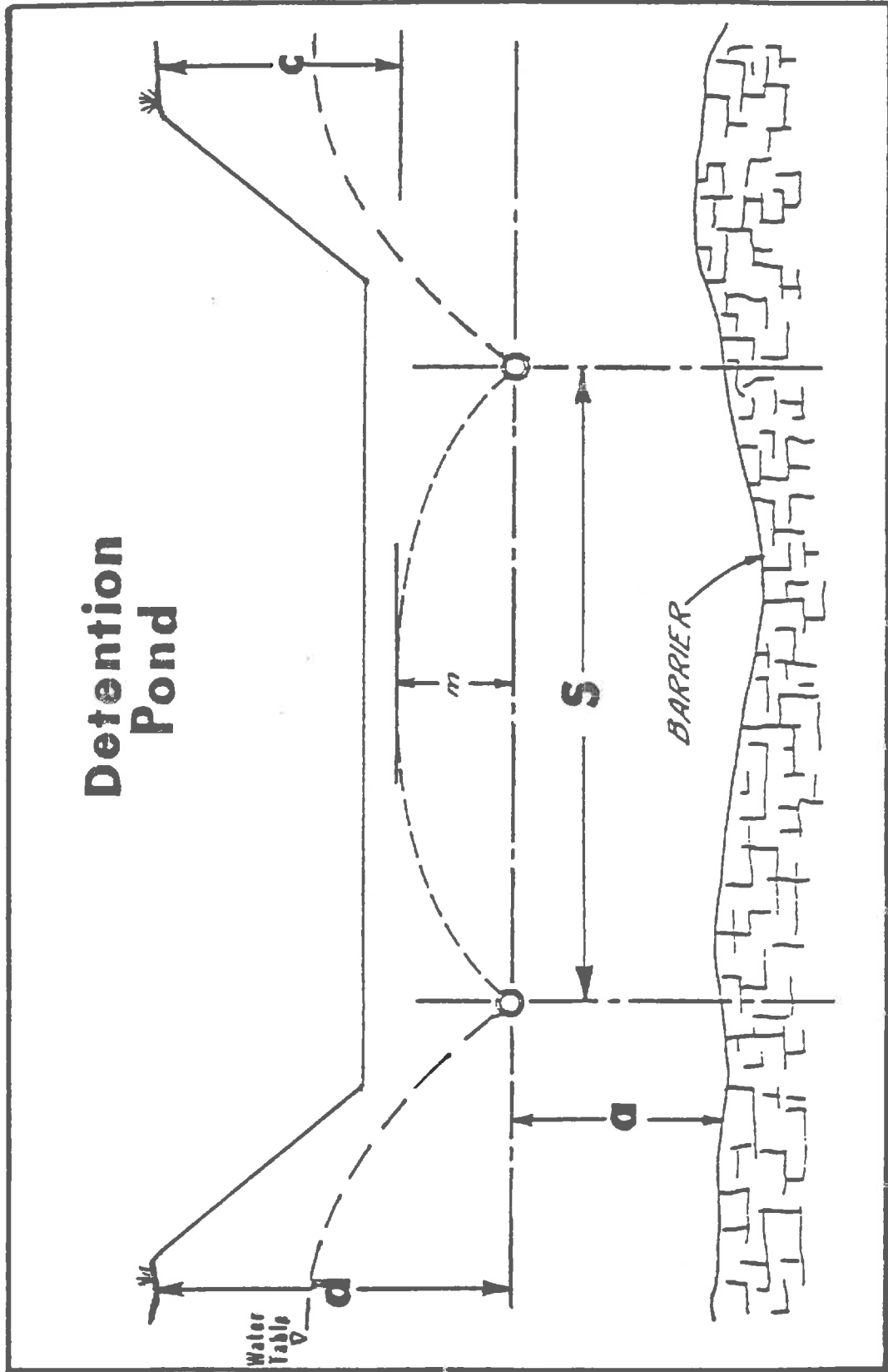

The ellipse equation is based on the assumption that groundwater accretion from outside the given area is slight. Although it is known that this assumption is only approximate, it may approach actual conditions very closely under certain site conditions. For this reason use of the formula should be limited to the following conditions:

- 1) Where the hydraulic gradient of the undisturbed water table is one percent (0.01 feet per foot) or less. Under these conditions there is likely to be very little groundwater flow or movement from outside the facility.
- 2) Where soil and subsoil materials are underlain by a barrier at relatively shallow depths (twice the depth of the drain or less) which restricts vertical flow and forces the percolating water to flow horizontally toward the drain.
- 3) Where a gravel envelope or porous sandy backfill materials are used such that there is a minimum of restriction to flow into the drain itself.

The depth of the drain must be determined before the spacing may be computed by formula. As noted above, a minimum depth of 2 feet should be maintained for mineral soils such as those described for this example project. This is especially important for facilities where heavy mowing equipment or other large vehicles are likely to be used for maintenance.

The following illustrates the use of the equation. (NOTE: Variable (a) should not exceed the value of variable (d) to be within the limits of the assumptions associated with the use of the formula). Working through the various factors of the equation:

- 1) Assuming 6-inch diameter underdrains are to be installed at the minimum depth recommended for mineral soils (2 ft), the depth to the flow line of each drain would equal 5.25 ft. (d), since the desired pond depth is 3 feet and the radius of the pipe is 3 inches or 0.25 ft.
- 2) As specified earlier the soils information indicates a restrictive layer at a depth of 80" or six and one-half feet. Therefore, $a = (6.5 - d) = 1.25$ ft.
- 3) The system should be capable of lowering the water level to the pond bottom within 24 hours following storm events if improved grass varieties are to be used as a cover crop or if the storage area is to serve other purposes such as parks and recreation. Assuming the storage area is to be sodded with lawn grass, the depth to water table after drawdown in the vicinity of facility would be equal to the depth of the pond, therefore $c = 3.0$ ft and $m = (d - c) = 2.25$ ft.

- 4) The average hydraulic conductivity was specified earlier. (K = 10 in/hr).
- 5) The applicable drainage coefficient is:

$$q = c/t = \frac{3.0 \text{ ft.}}{da} = 1.50 \text{ in/hr.}$$

Substituting the values specified above into the Ellipse Equation:

$$S = \frac{[4(10)(2.25^2 + 2(1.25)(2.25)]}{1.5}$$

$$S = 16.9 \text{ or } 17.0 \text{ ft.}$$

In actual practice this value may be adjusted slightly to conform with tract dimensions. Suppose the dimension of the facility perpendicular to the direction of the underdrains is limited to 100 feet. Five drains equally spaced (20 ft) would slightly exceed the recommended spacing however, this spacing is within adjustment limits.

Based on the Ellipse Equation, Table 6-14 presents values of (S) or the width in feet over which a subsurface drain would be estimated to be functional given a number of drain depths, soil permeability rates (k) and drainage coefficients (q).

TABLE 6-14

Underdrain Spacing Chart
(based on Ellipse Equation)

q* (in/hr)	k (in/hr)	Drain Burial Depths(ft)		
		1	2	3
		(S)	Spacing	(ft)**
0.5	1	4.9	9.8	14.7
	10	15.5	31.0	46.5
0.33	1	6.0	12.1	18.1
	10	19.1	38.1	57.2
0.167	1	8.5	17.0	25.4
	10	26.8	53.6	80.4

*Drainage rates required respectively to drawdown 3-feet, 2-feet, and 1-foot

$$** S = \frac{[4K (m^2 + 2 am)]^{1/2}}{q} \text{ where:}$$

- S = spacing (ft.)
- q = drainage rate from column #1 (in/hr.)
- k = soil permeability rate from column 2 (in/hr.)
- m = drain burial depth (ft.)
- a = depth of barrier below drain equal to drain burial depth (ft.)
(e.g., a = m)

It should be noted that the values of (q) listed in Table 6-14 from top to bottom represent the drainage rates which would be needed to drain 3-feet, 2-feet, and 1-foot of water from the holding area over a 72-hour period. This is the maximum time frame allowed according to specifications adopted by the state. Such limitations are needed primarily for mosquito control purposes, and to ensure a high level of treatment of the average annual rainfall volume based on storm frequency analysis. As can be seen from the table, the deeper the drain, the greater the space over which it can be expected to remove the required amount of water. Likewise the spacing increases as the depth in the holding area is reduced and/or as the permeability of the surrounding base material (soil) increases.

3) Calculate the Length of Underdrain Required

A quick estimate of the length of underdrain can be determined by dividing the value of spacing (S) into the average area of the storage facility. The area was specified in step one of the design procedure ($A = 7260 \text{ ft}^2$). Therefore, the length of the underdrain system would equal 7260 square feet divided by the 20.0 foot spacing or 363 ft.

To prevent damage to the cover crop due to erosion and/or seepage, it is usually desirable to keep both the bottom and sides of the detention area dry. Using the top dimensions to determine the configuration of the underdrain can help ensure this function. Suppose the installation in the direction perpendicular to the underdrains is limited to 100 feet and the designer wants the pond to be a maximum of 3-feet deep. Assuming the slope of the sides and shape of the storage area are known, it is possible to determine the top width of the facility and the exact length of drain tile needed.

For example, suppose that the basin is to be rectangular shaped, 3-feet deep, 100 feet along the top, with 3:1 side slopes. A detention area with a top width equal to 88.8 feet, would be capable of storing the required volume of runoff ($21,780 \text{ ft}^3$). The area served by each lateral in the system would equal the spacing (S) times the length of the drain (L) plus one-half the spacing at each end $2(S/2)$. In equation form, $A = S(L+S)$. As illustrated in Figure 6-39 the length of each lateral (L) would be equivalent to the top width of the facility (88.8 ft) minus two times one-half the spacing $(2)(S/2)$ or (20.0 ft) which gives $L = 68.8 \text{ ft/lateral}$. Since five laterals will be needed as specified earlier, the total length of underdrain laterals (L) would equal 344 feet. In mathematical terms

$$\text{Total Length of Laterals} = L \times 5 = \boxed{344 \text{ ft}}$$

FIGURE 6-39
Sketch of Typical Underdrain System
Illustrating the Area Served by Laterals

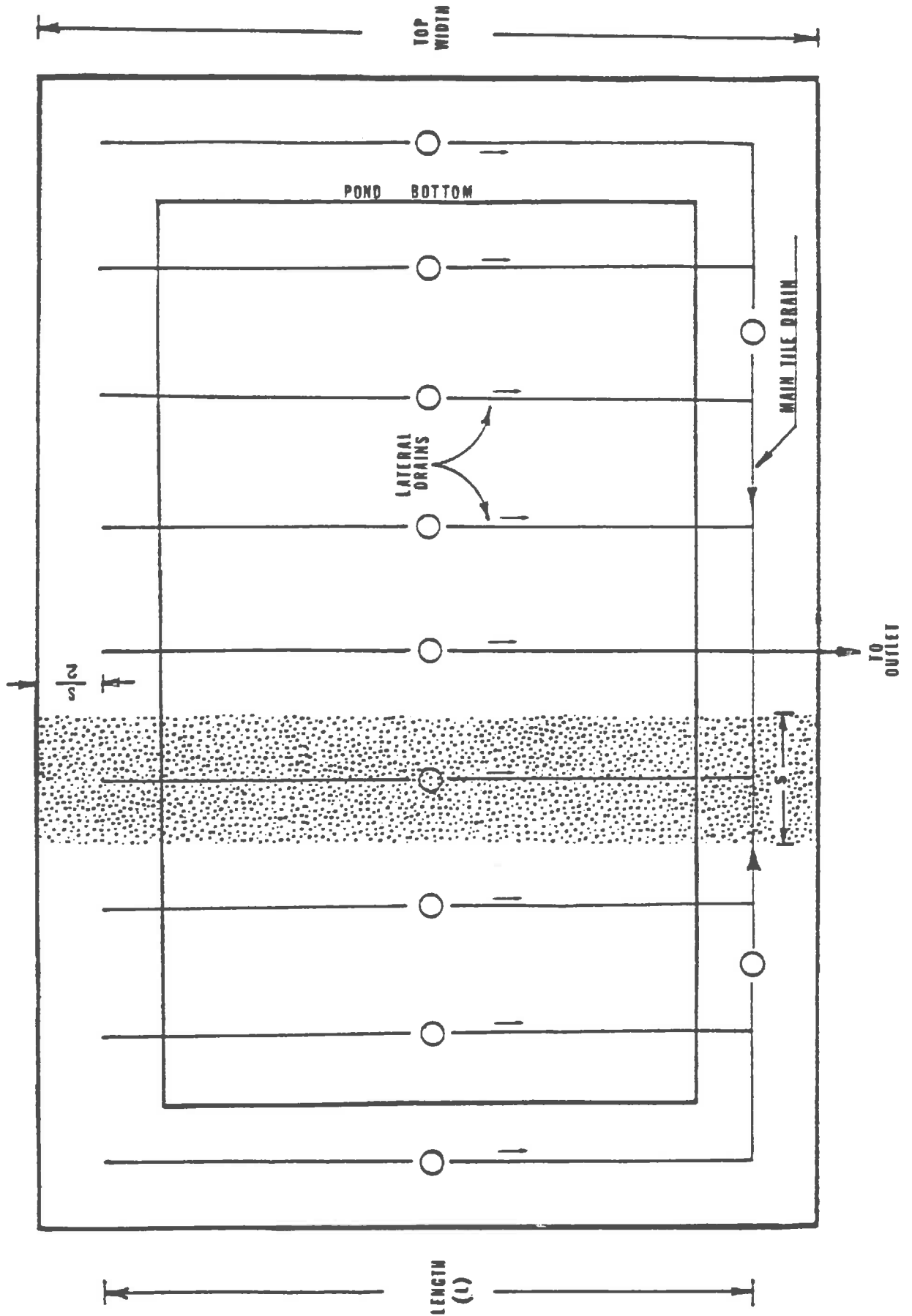

4) Estimate Design Capacity

The size of the drain may be found by determining the discharge using the following formula.

$$Q_r = \frac{q S(L + S)}{43,200}$$

Where:

Q_r = Relief drain discharge (c.f.s.)

q = Drainage coefficient (in/hr.)

S = Drain spacing (feet)

L = Drain length (feet)

In this example: (Assuming a 3' deep pond)

Drain spacing = 20.0 feet (S)

Drain length = 344 feet (L)

Drain coefficient = 1.50 in/hr (q)

$$Q_r = \frac{1.50 \times 20.0 (344 + 20)}{43,200} = \boxed{0.25 \text{ cfs.}}$$

5) Determine Drain Diameter, Sizing Underdrains

Subsurface drains ordinarily are not designed to flow under pressure. The hydraulic gradient is considered to be parallel with the grade line of the underdrain. The flow in the drain is considered to be open-channel flow. The size conduit required for a given capacity is dependent on the hydraulic gradient and the roughness coefficient--"n" value--of the drain. Commonly used materials have "n" values ranging from about 0.011 for good quality smooth plastic pipe to about 0.025 for corrugated metal. When determining the size of drain required for a particular situation the "n" value of the product to be used must be known. This information will normally be available from the manufacturer. The diameter pipe required for a given capacity, hydraulic gradient, and four different "n" values may be determined from Figures 6-40, 41, 42 and 43.

Example: Assume an underdrain on a 0.2% grade ($s = 0.002$) is to discharge 0.25 cubic feet per second. What size drain will be required if the material to be used has a roughness coefficient of 0.015? Find the hydraulic gradient 0.002 on the horizontal scale in Figure 6-40 then follow vertically upward to intersect the line representing the design discharge of 0.25 cubic feet per second. This point falls in the space between the lines marked 6 to 8 inches in diameter therefore, an 8-inch drain is required. Since the point of intersection is below the line marked 8 inches, the drain will not flow full. The full capacity of the drain is 0.47 cfs therefore, the drain will flow about 50% full for the design discharge. The same procedure is followed when using Figures 6-40, 41 and 43 for roughness coefficients of 0.011, 0.013, and 0.025, respectively.

FIGURE 6-40

Subsurface Drain Capacity Chart - "n" = 0.011
(Source USDA-SCS)

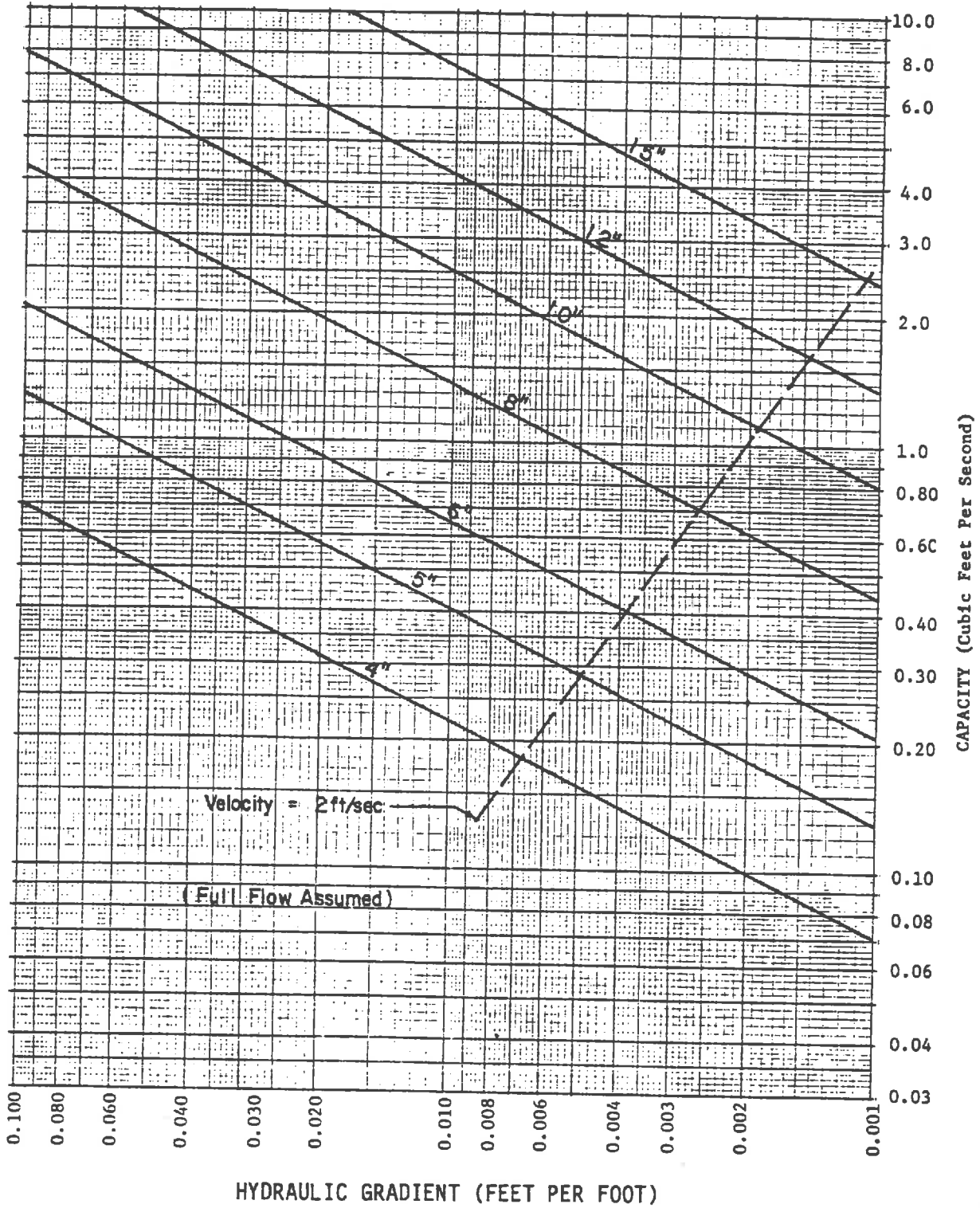

FIGURE 6-41

Subsurface Drain Capacity Chart - "n" = 0.013
(Source USDA-SCS)

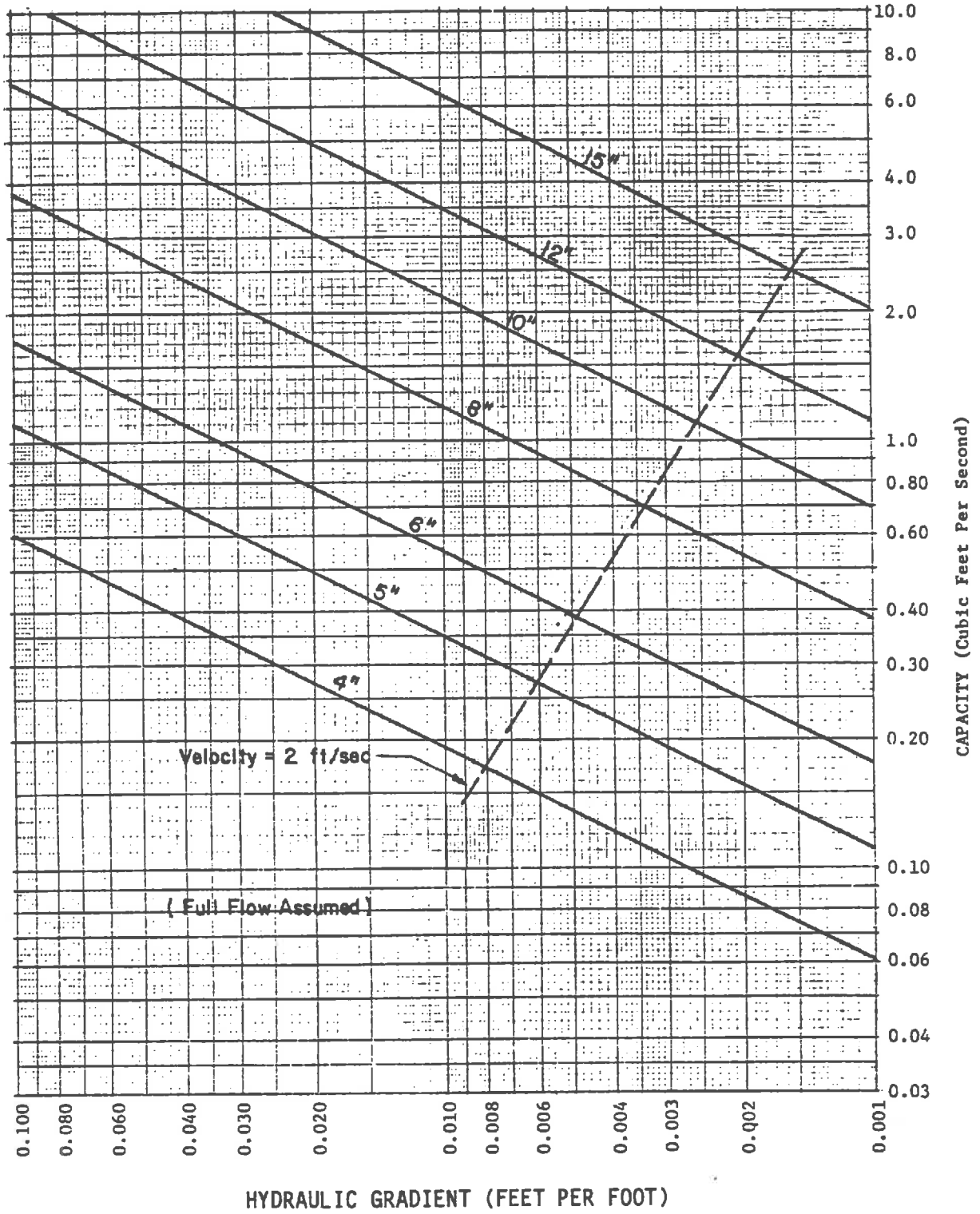

FIGURE 6-42

Subsurface Drain Capacity Chart - "n" = 0.015
(Source USDA-SCS)

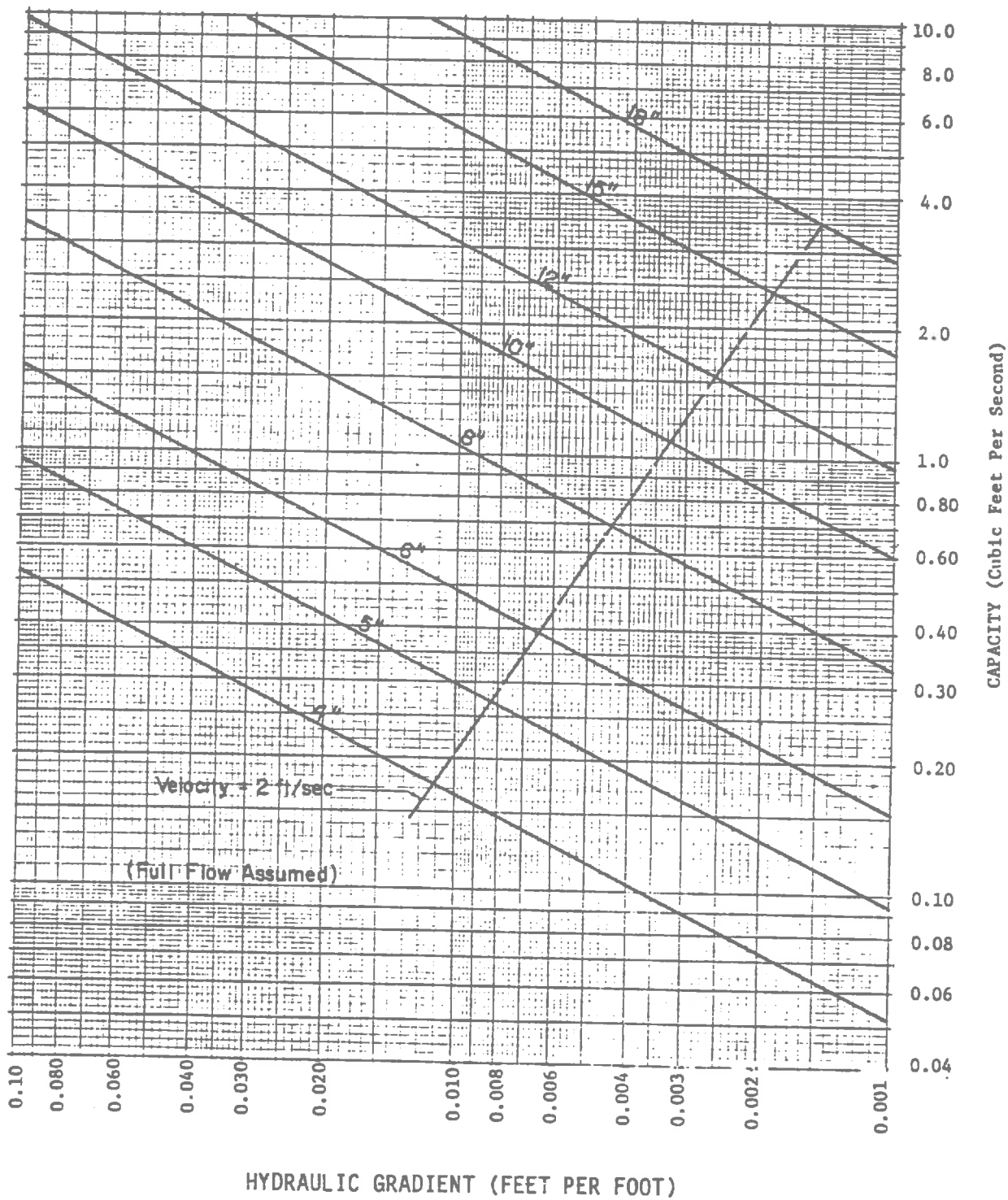
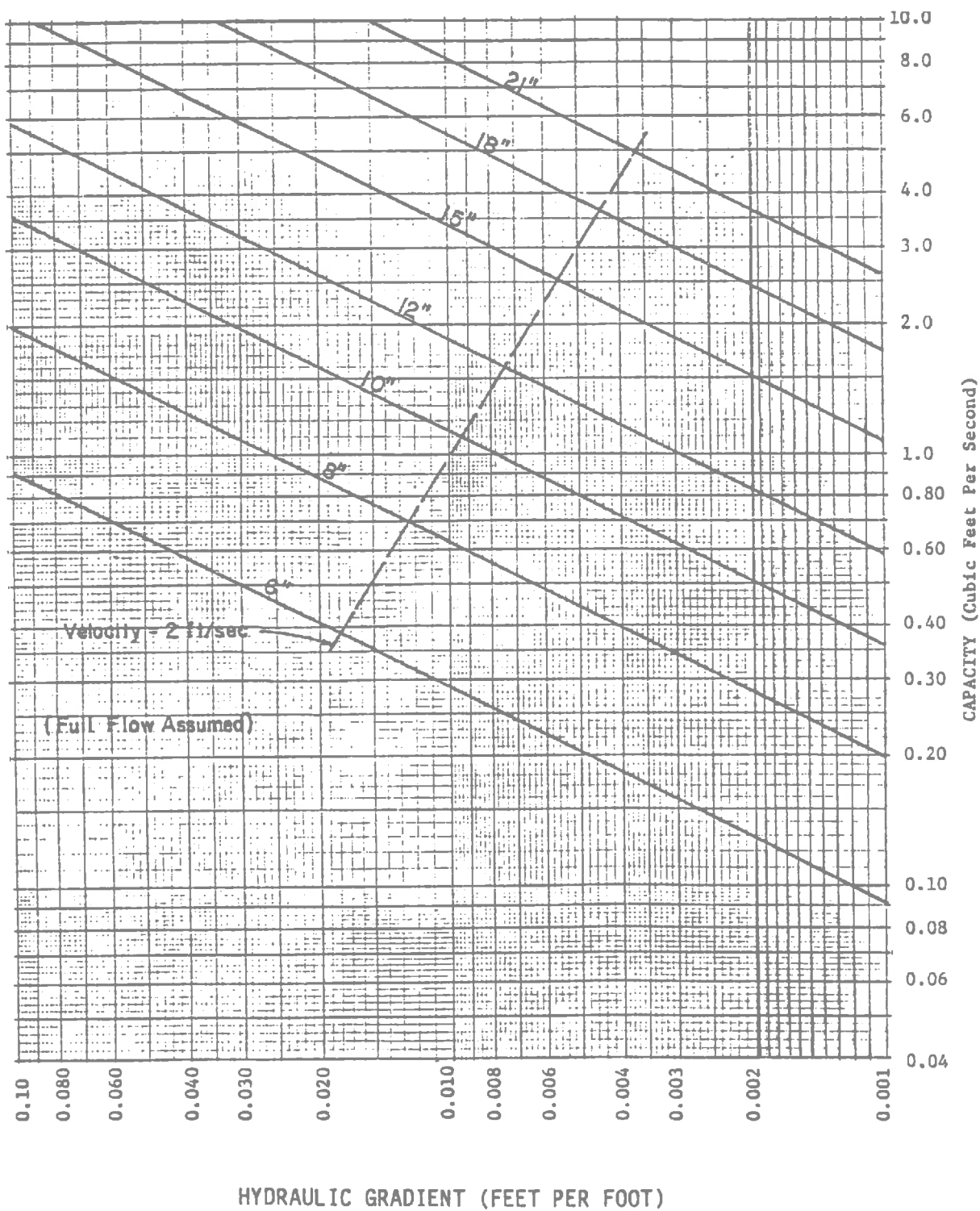

FIGURE 6-43

Subsurface Drain Capacity Chart - "n" = 0.025
(Source USDA-SCS)



Most filtration and underdrain systems currently being installed throughout the state use a minimum of 6" pipe. Smaller diameters may be used, however, it is presently recommended that the pipes be no smaller than 4-inch material. The area to the right of the broken line in the charts indicates conditions where the velocity of flow is expected to be less than 2.0 feet per second. For a field scale, agricultural subsurface drainage system lower velocities may present a problem with siltation in areas of fine soils. Underdrain and filter beds for urban stormwater treatment should be designed to remove much of the fine solids portion of the particulates being carried in the runoff. Due to the sandy nature of the soils over much of Florida, maintaining velocities greater than 2.0 ft/sec is usually not critical. However, a filter or underdrain system must be designed with this in mind in order to be effective. A layer or combination of layers of pervious materials must be used and installed in a manner to provide for water movement yet prevent the migration of soil particles due to flowing water. In most cases, it is felt that systems designed to the specification contained in the Stormwater Rule should be capable of meeting this goal.

6) Sizing of drains within the drainage system

The previous discussion on drain size deals with the problem of selecting the proper size for a drain at a specific point in the stormwater system (the outlet). In drainage systems with laterals and mains, the variation of flow within a single line may be great enough to warrant changing size in the line. This is often the case in long drains or systems with numerous laterals. The following example illustrates a method for such a design.

Example:

Assume that the total discharge from 344 feet of smooth perforated plastic underdrain is to be .25 cfs, that no surface water is admitted, and that the accretion to the drain is uniform throughout its length. Also assume a constant grade of 0.20%. The accretion per 100 feet of drain would be $\frac{0.25}{3.4} =$

.07 cfs. The "n" value of the pipe to be used is listed as 0.011. Use Figure 6-40 to determine the sizes of tile required. Start the design process at the upper end of the drain using a minimum size of 4 inches. First compute the distance that the drain would carry the flow on the assumed grade. Let (L) equal the distance (in 100-foot sections) down gradient that a 4-inch drain would be adequate. Referring to Figure 6-40, a 4-inch tile with a slope of 0.20% or .002 feet per foot has a maximum capacity of 0.10 cfs and:

$$L = \frac{0.10}{.07} = 1.4 \text{ (100-foot sections)}$$

The 4-inch drain is adequate for 140 feet of line. Continue these calculations for the next size pipe (5-inch) which has a maximum capacity of 0.18 cfs.

$$L = \frac{0.180}{0.070} = 2.60 \text{ (100-foot sections)}$$

The 5-inch drain would be adequate for 260 feet. Of this 260 feet, 140 feet would be 4-inch drain; and the remaining 120 feet would be 5-inch drain. These computations should be continued progressively for the total length of the system. The following tabulation shows the complete problem:

Tile Size	Maximum Capacity .20% Grade	Accretion per 100' Line	L-Value Number of 100 Foot stations	Length of Tile Required
inches	c.f.s.	c.f.s.	stations	feet
4	0.10	0.07	1.4	140
5	0.18	0.07	2.6	120
6	0.29	0.07	4.1	84 ¹
				<u>344</u>

¹Total length of the drain desired is 344 feet. Although the 6-inch tile would be adequate for 150 feet, only 84 feet are needed.

The example assumes a single line with uniform accretion throughout its length. If investigations indicate a variation in permeability, the accretion rate per 100 foot station may be varied. The same procedure is applicable for mains in a system where laterals join at regular intervals. In this case the accretion to the main would be the accumulative discharges of each of the laterals at intervals equal to the drain spacing.

Example:

Assume that the configuration of the underdrain system being considered is similar to the design illustrated in Figure 6-39 but it has only five lateral drains. One drain line connects into the main drain at the middle, opposite the outlet, followed by two laterals of equal size spaced 20 feet apart on each side. In other words, the total length of the main tile drain runs 40 feet in each direction from its midpoint at the outlet. Further assume that the total discharge expected from the system is 0.25 c.f.s. and that all the other presumptions made in the preceding example also pertain.

Begin by estimating the accretion per lateral. Since each line is of equal length this may be accomplished simply by dividing the total discharge by the total number of lines which feed into the main tile drain. In this case, $0.25 \text{ c.f.s.} / 5 \text{ laterals} = 0.050 \text{ c.f.s. per lateral}$. From Figure 6-40, 4-inch drain tile with a grade of .002 feet per foot has a discharge capacity of 0.10 c.f.s. Therefore, 4-inch pipe is adequate to handle the accretion expected per lateral. Each line would function at 50% of total capacity (e.g., .050 c.f.s. compared to the 0.10 c.f.s. maximum discharge ability).

Given the "T" shaped configuration of the outlet pipe and main tile drains as shown in Figure 6-39 the accretion in each 20-foot section of main tile drain would be .050 c.f.s. at the first lateral plus .050 c.f.s. for each additional lateral or 20.0 foot station. Use Figure 6-40 to determine the sizes of pipe required for the main tile drain. Start computation at the upper end of each main with a minimum size equivalent to the diameter of the laterals. In this instance begin with 4-inch pipe. Compute the distance down drain that it would carry the flow on the assumed grade. Let (L) equal the distance that a 4-inch tile would be adequate. This number must be reduced by the number of laterals which enter at the upper end or head of each main (in this case, one). As noted earlier, a 4-inch drain on a grade of 0.20% has a maximum capacity of 0.10 c.f.s. and:

$$L = \frac{0.10}{.05} - 1 = 1.00 \text{ (20 ft. sections)}$$

The 4-inch pipe size is adequate for the first 20 feet on each side of the main tile drain. Continue these calculations for the next size tile (5-inch). From Figure 6-40 the 5-inch plastic pipe has the capacity to carry 0.18 c.f.s. assuming a constant grade of 0.20%. Therefore;

$$L = \frac{0.18}{0.05} - 1 = 2.6 \text{ (20 ft. sections)}$$

The 5-inch drain would be adequate for 52 feet (2.6 x 20 ft. per section). Of this 52 feet, the first 20 feet would be 4-inch pipe. Given the configuration of this system the remaining 20 feet must be increased to 5-inch drain. These computations should be continued for the total length of main drain. However, in this example each main tile line is designed to be 40 feet long in each direction. The following tabulation illustrates the complete problem.

Tile Size inches	Maximum Capacity .20% Grade c.f.s.	Accretion per 20' Line c.f.s.	L-Value Number of 20 Feet stations	Length of Tile Required feet
4	0.10	0.050	1.0	20
5	0.18	0.050	2.6	20
				40

Continue calculations to determine the size of the outlet pipe required. Once again refer to Figure 6-40 to determine the size of smooth plastic drain pipe required. Procedures for selecting the proper size for a drain

at a specific point in a system were discussed earlier. In this example the designer must estimate the discharge capacity for plastic pipe (n value = 0.011).

Find the hydraulic grade 0.002 ft/ft. or .2% on the horizontal scale in Figure 6-40 and follow vertically upward to intersect the line representing the total design discharge from the five laterals (e.g., 0.25 c.f.s.). This point falls in the space between the lines marked 5 to 6 inches in diameter. Therefore, a 6-inch diameter pipe is required. The pipe will not flow full since the capacity of the drain is 0.29 c.f.s.

The final design for the underdrain system would consist of five laterals each 4 inches in diameter spaced equally at 20 feet apart. Each of the main tile drains would be 40 feet long. The first 20 feet would be 4-inch diameter pipe and the final 20 feet to the outlet must be five-inch diameter drain. The outlet must be sized to handle 0.25 c.f.s. therefore six-inch diameter pipe is required.

PART-II

Design Criteria for Stormwater Filtration Facilities

Filter systems for stormwater quality renovation may be used in conjunction with either wet or dry detention facilities. The bottom elevation of the former is below the grade line of the underdrain pipe. Conversely, subsurface drains are normally located in the lowest portion and below the bottom of dry detention facilities.

Examples of stormwater filtration systems include:

- 1) Filter systems in the banks of wet detention facilities. A typical cross section is illustrated in Figure 6-44. A slightly modified version of this particular style of discharge control structure is shown in Figure 6-45. The major difference between the two consists of a "flash board" type riser for adjustable depths of detention and flood control. Also notice that underdrains enter at the base of the riser pipe in the system shown in Figure 6-45 as opposed to entering somewhere along the outlet pipe as shown in Figure 6-44.
- 2) Bank filter systems used in conjunction with online or offline wet detention facilities which use the natural in place soils for filtration in conjunction with underdrain pipe for drainage. (See Figure 6-46).
- 3) Raised filtration beds projecting outward toward the center or extending along the sides of wet or dry detention facilities. (See Figures 6-47, 48, 49 and 50).

FIGURE 6-44

Cross-Section of Stormwater Discharge Structure with "Mixed Media" Bank Filter System (Wet Detention Facility)

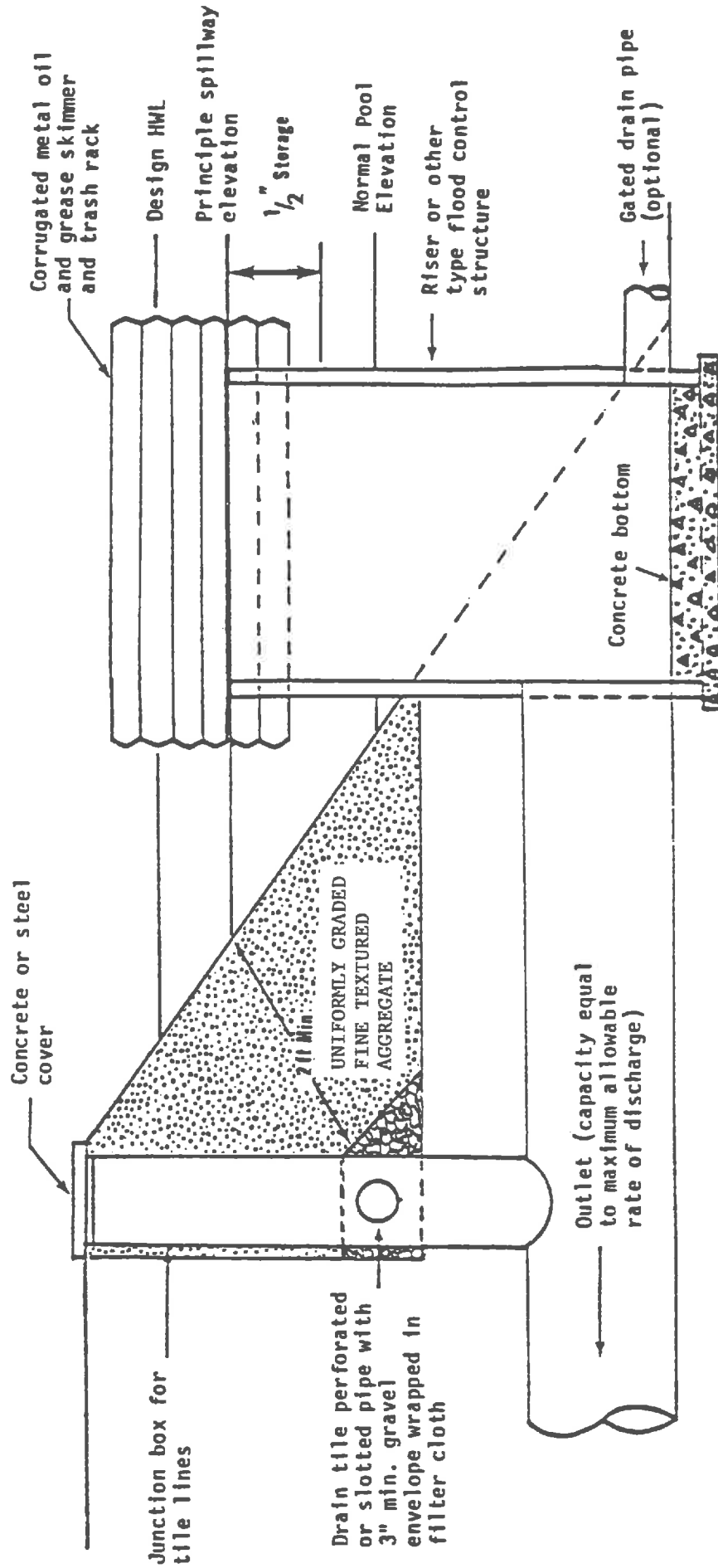
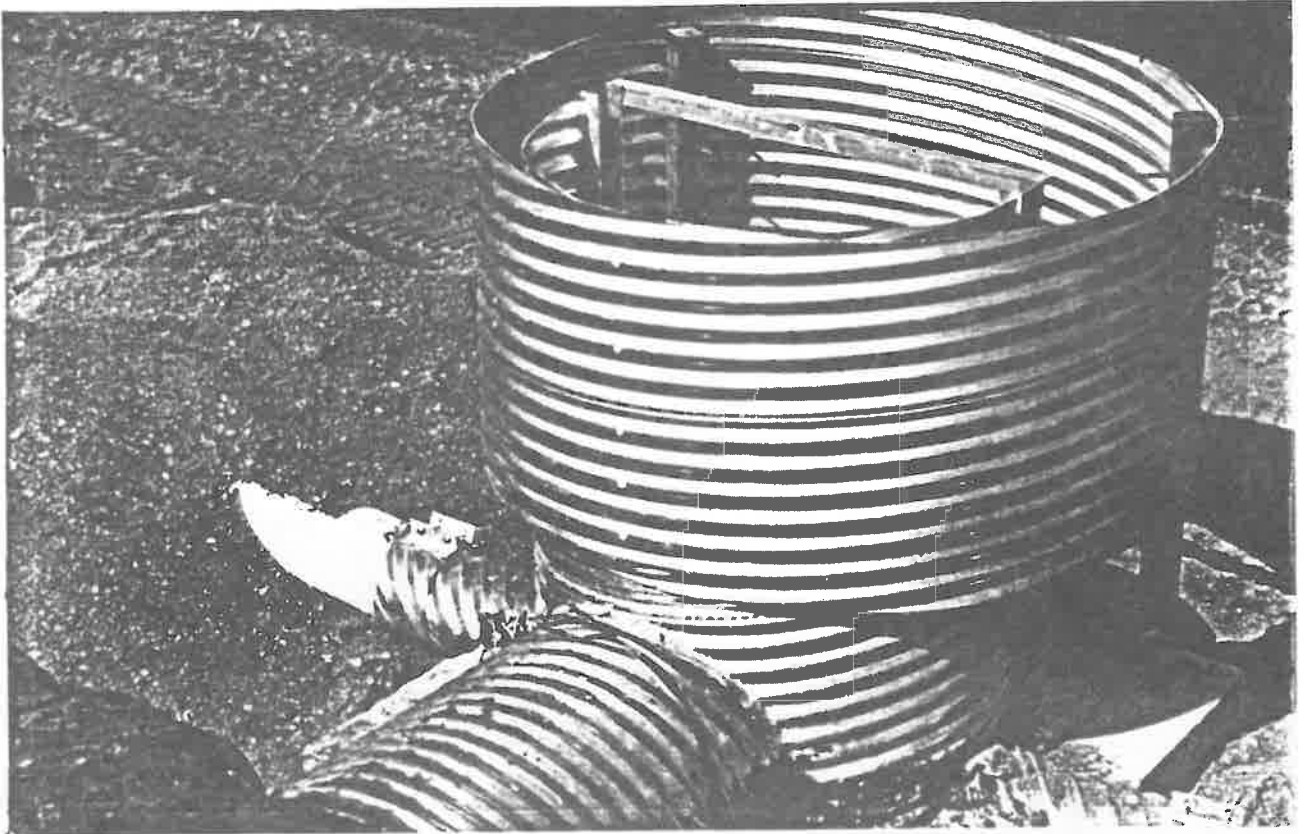

FIGURE 6-45

Typical Stormwater Control Structure @ Orlando Jetport with Bank Filter or Underdrain Pipe to Treat Runoff and Flash Board Riser for Adjustable Levels of Retention and Flood Control



This unit is a custom prefab. The structure consists of a 30-inch outlet pipe, 48-inch riser, and 12-inch underdrain headers; all aluminum construction. (It is suitable for both wet or dry detention facilities).

(Courtesy of Mr. Charles King, P.E., Greiner Engineering Sciences, Tampa, Florida).

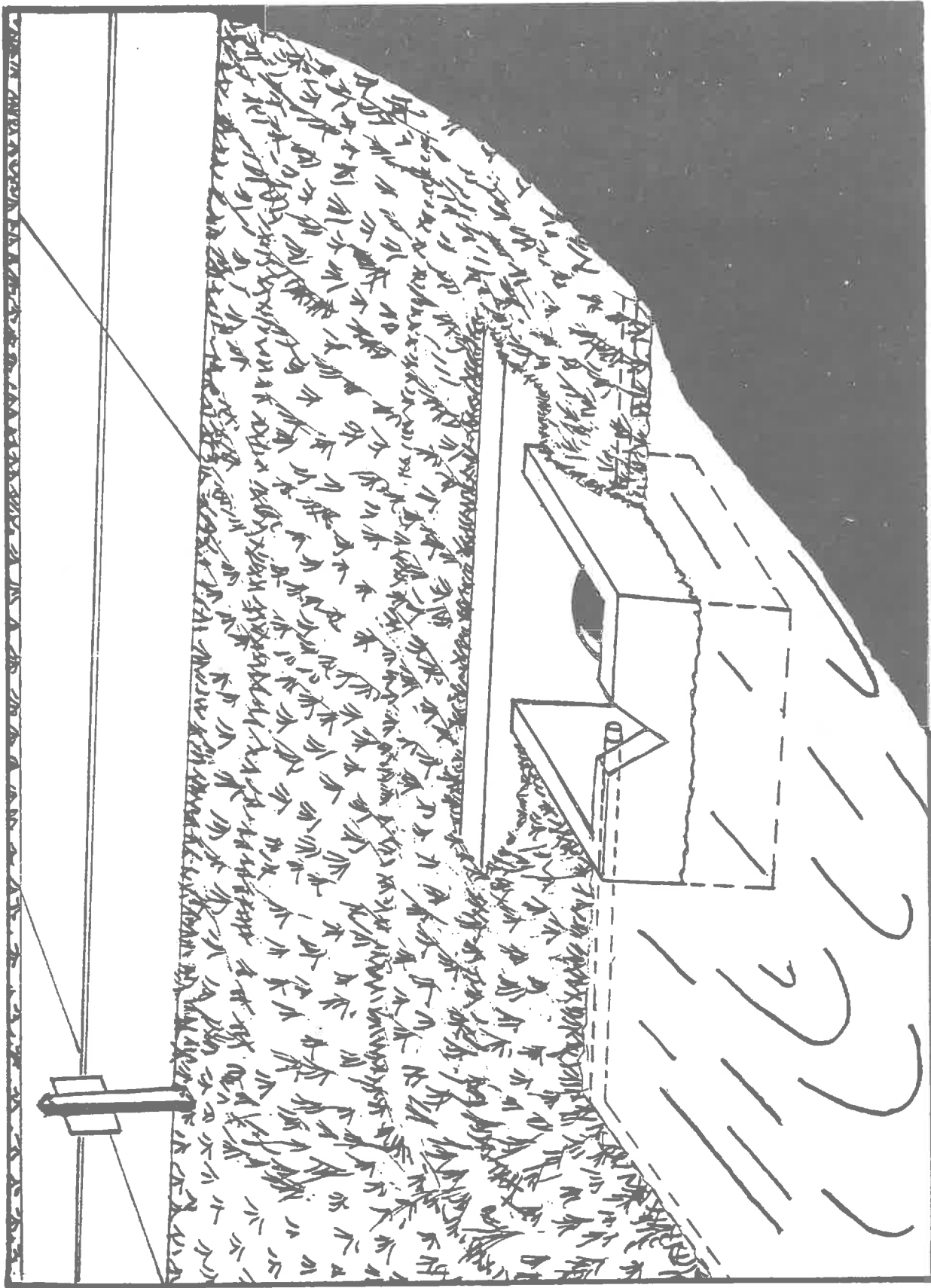

FIGURE 6-46

Illustration of Typical "Natural Soil" Bank Filtration System with Box Inlet Drop Spillway and "v" Notched Weir. (Wet Detention Facility)

FIGURE 6-47

TYPICAL SUBDIVISION LAYOUT SHOWING ON-LINE DETENTION POND AND OUTFALL
(Courtesy of Pinellas Park Water Management District)

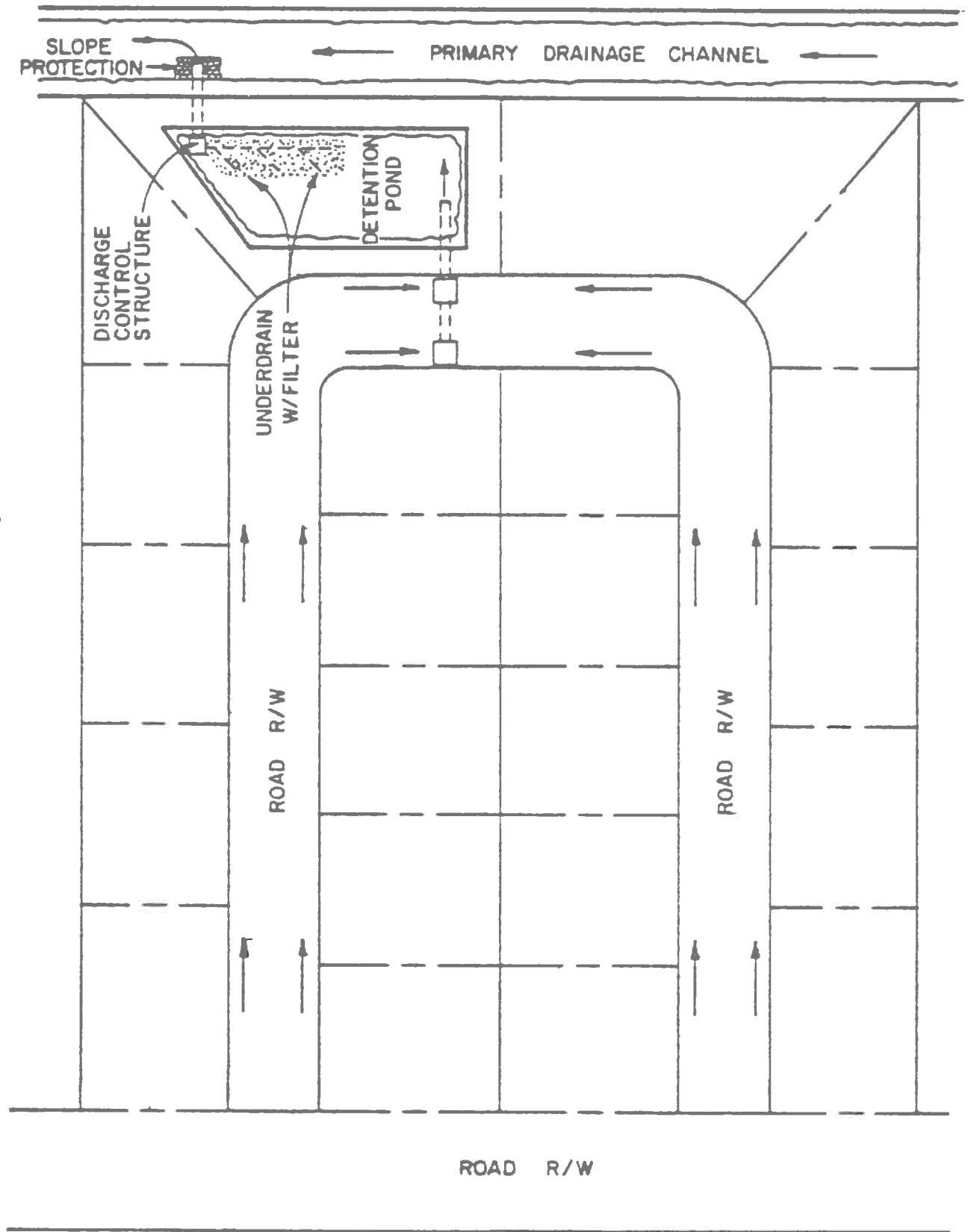
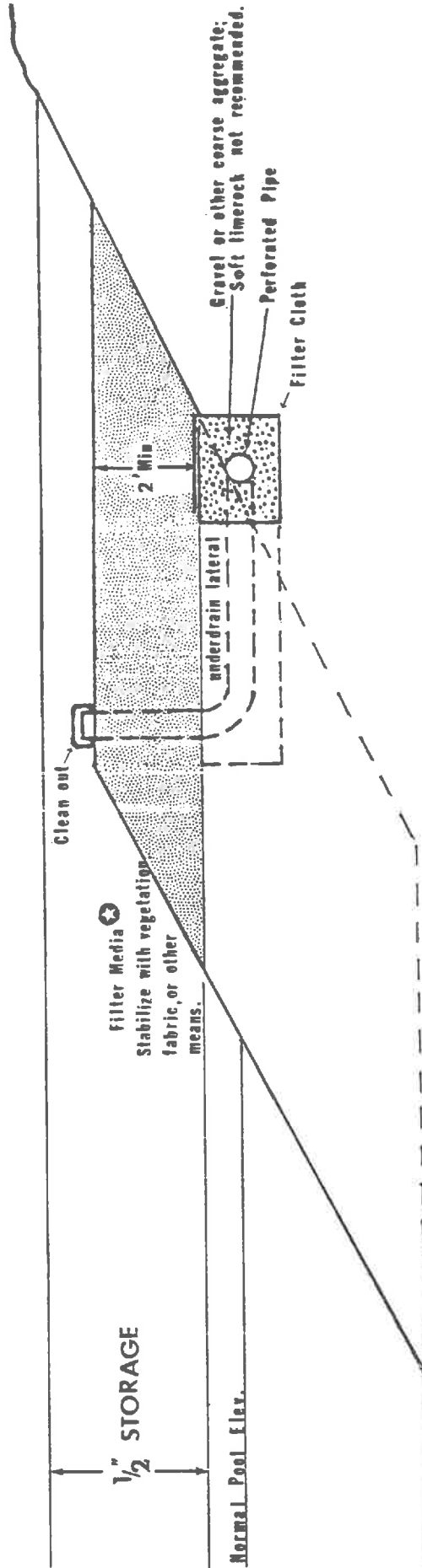

FIGURE 6-48

Typical Cross-Section of Elevated Bank Filtration Bed Used in Conjunction with Wet Stormwater Detention Facilities

SECTION A-A



- ⊗ Effective Size $\leq 0.55\text{mm}$.
- Uniformity Coefficient ≥ 1.5
- Washed; no more than 1% fines recommended

FIGURE 6-49
 TYPICAL SUBDIVISION LAYOUT SHOWING OFFLINE DETENTION POND AND OUTFALL
 (Courtesy of Pinellas Park Water Management District)

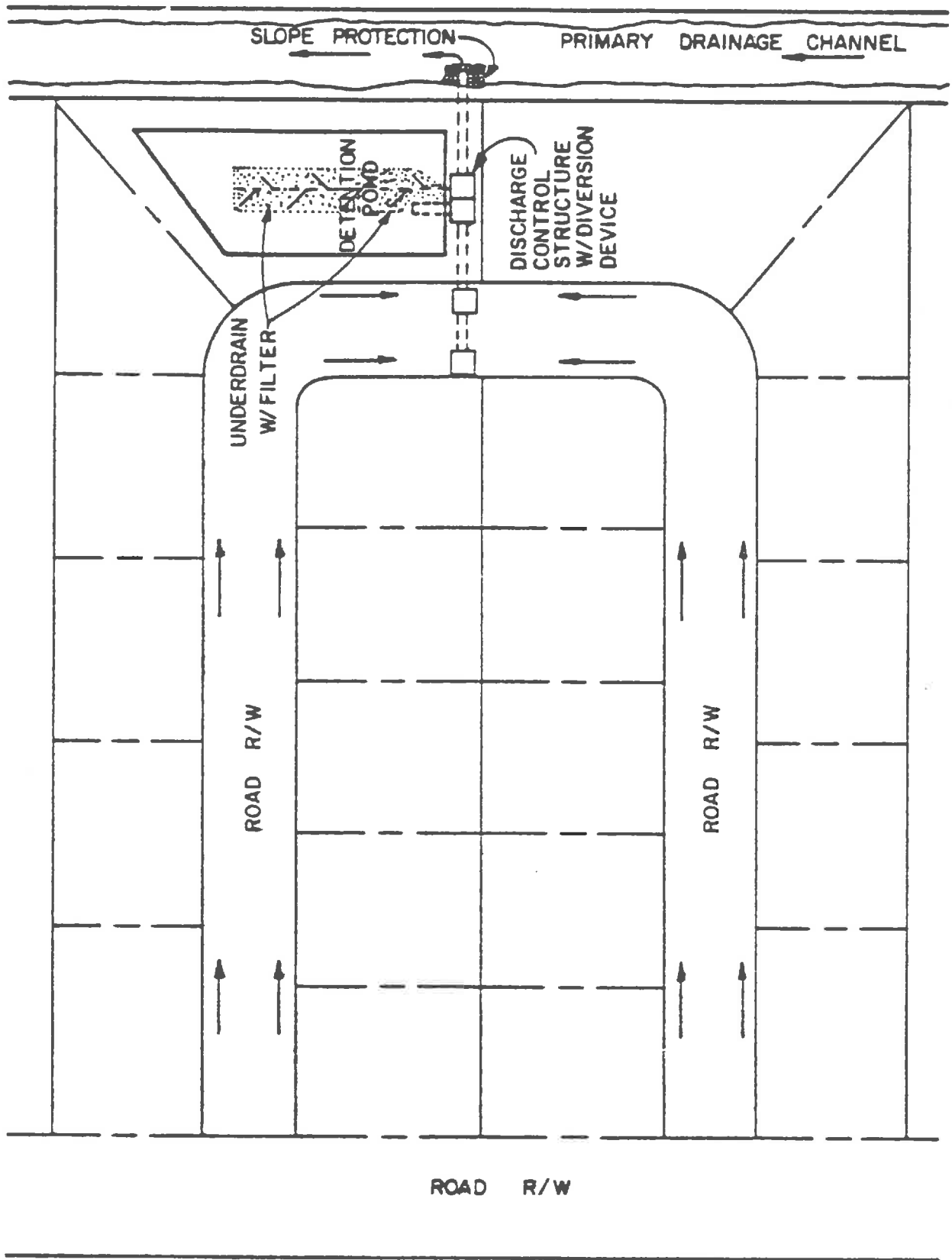
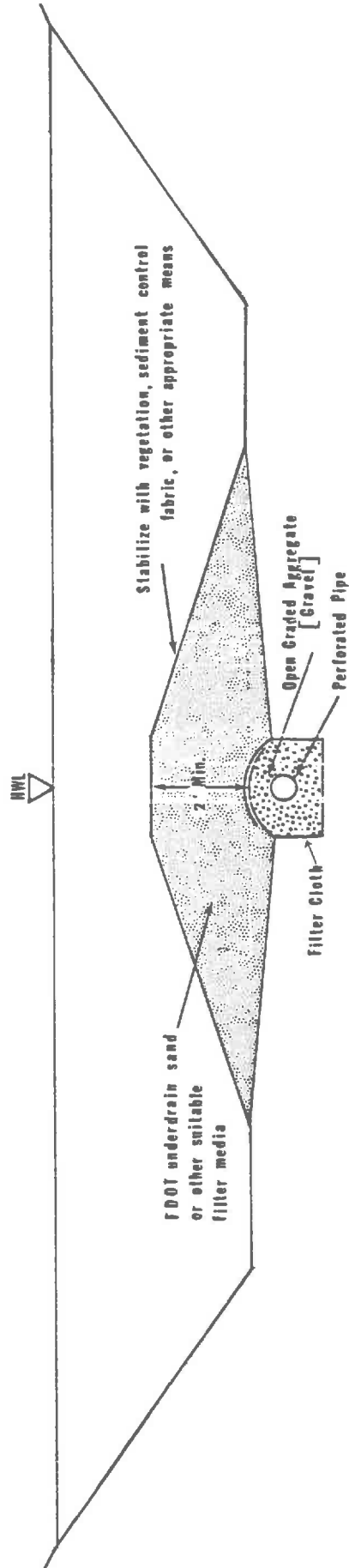

FIGURE 6-50

Typical Cross-Section of Elevated Sand Filter for Stormwater Treatment Used in Conjunction with Dry Detention Facility



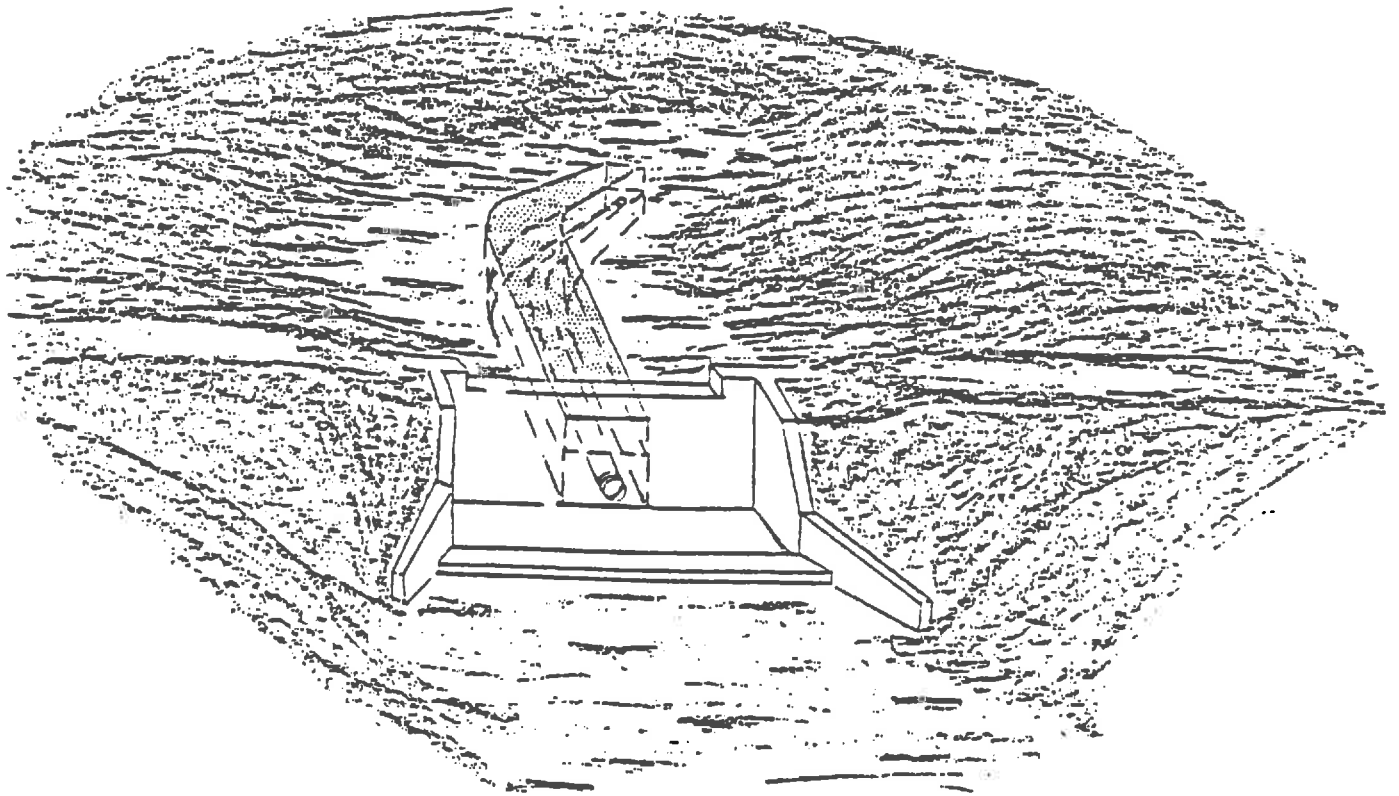

FIGURE 6-51

Illustration of Bottom Filter or Underdrain System in
Conjunction with Rectangular Weir and Drop Spillway
(Normally Used with Dry Detention Facilities and
Swales on Tight Soils and/or Steep Slopes)

- 4) Sand filter systems installed in the bottom of swales to improve percolation. (See Figure 6-51).

How does the Stormwater Rule standards listed in Chapter 17-25, F.A.C., affect these systems?

Underdrain systems and bank filters which use natural soil for filtration do not have to meet the requirements in section 17-25.025(2), F.A.C. pertaining to effective grain size, uniformity coefficient, etc.

However, these systems must be designed to prevent piping both within and through the filter. They are also subject to the 2 feet minimum flow requirements specified in Section 17-25.02(8), F.A.C.

Filter systems which use an aggregate other than natural soil for filtration must satisfy the standards listed in Section 17-25.025(2), F.A.C. The current standards for filter media are summarized and noted at the bottom of Figure 6-48.

Material with effective sizes less than .20 millimeters are acceptable to the Department for pollution control purposes. However, applicants may find the permeability to be restrictive.

Likewise, material mixed with organic matter or colloidal material may improve pollutant removal. However, anything more than slight amounts of material less than 0.074 millimeters in size has the potential to reduce hydraulic capacity quite substantially. The improvement in removal efficiency of such practices is still being tested by Dr. Wanielista and others at this time.

Design Procedures for Sizing Stormwater Filtration Systems

Underdrain design procedures will often involve the use of "spacing equations" to determine the area over which the drainage network can be expected to function to drain the proper amount of water in the required time frame.

Filter systems are usually designed by trial and error. In this procedure drainage capacity is checked for compliance with various regulations until a suitable configuration (e.g., trench area, depth, pipe diameter, and hydraulic conductivity of filter media) is achieved to meet drawdown time and grain size requirements. In terms of stormwater treatment, the Department is interested in the various design procedures from the standpoint that underdesign will result in reduced hydraulic capacity. This, in turn, will result in a reduction in storage between subsequent rainfall events and an associated decrease in the annual average volume of stormwater treated resulting in a reduction of pollutant removal. Such circumstances also reduce the aesthetic value of the system and may promote mosquito production.

In most cases, various forms of the Darcy Equation for saturated flow through porous media are used to design filters. The equation is written:

$$Q = K i A$$

Where:

- Q = Flow in ft³/hr
- K = Permeability rate of filter media (ft/hr)
- i = Hydraulic gradient (ft/ft)
- A = Area of the aquifer or water bearing strata intersected (ft²)

The basic equation is applied in a number of different ways.

- 1) Calculating the length of a bottom filter and determining drain pipe size.
 - a) Possibly the most simplistic application of the Darcy Equation involves a slight manipulation in the formula such that the designer may determine the length (L) of a bottom filter, as illustrated in Figure 6-52, to treat and dewater an area sized to hold either the first one-half inch of runoff or the runoff from the first inch of rainfall. The flow (Q) of water reaching the underdrain pipe is assumed equal to its average velocity as it moves through the filter profile multiplied by the cross sectional area of the aquifer or filter trench intersected.

The velocity of flow is assumed proportional to the soil hydraulic conductivity (K) at a hydraulic gradient of unity (i.e. i=1).

The cross-sectional area intersected (A) is usually assumed equal to the average width of the drain field or trench (W) times the length of the drain (L). In mathematical form:

$$A = WL \text{ and therefore, } Q = KiWL.$$

The drain length is unknown but can be determined by rearranging the equation if the width of the trench is known:

$$L = \frac{Q}{KiW}$$

The flow (Q) is based on the storage volume which must be removed in the time frame desired. (K) is determined based on field permeability test or other information. The value of (W) is determined at the discretion of the designer. Its value normally will vary depending on the depth of the drain and the size pipe required.

FIGURE 6-52

Cross-Section of Bank Filter Illustrating Parameters Used in Calculating Drawdown Time with Darcy's Equation for Lateral Flow Situations

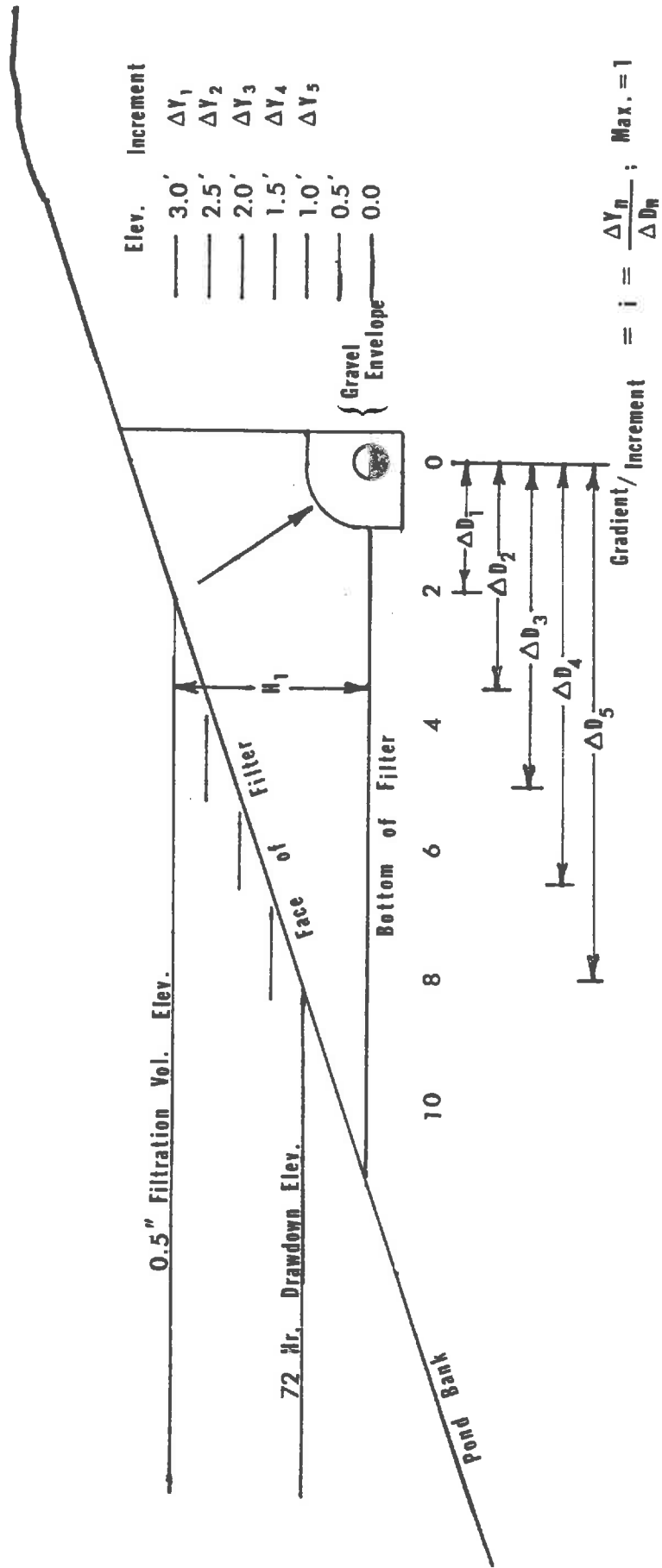

Example:

Suppose a facility is required to store one-half inch of runoff water per acre of project area as per state design criteria. Further, suppose the project is twenty acres in size with the hydraulic conductivity or permeability of the filter media (K) equal to ten inches per hour. The design calls for a three feet wide filter trench with the underdrain system installed two and one-half feet below the bottom of the detention facility for drawdown.

The length of filter and underdrain pipe needed to satisfy FDER criteria may be derived using the equation:

$$L = \frac{Q}{KiW}$$

Based on information presented in the paragraph above the one-half inch volume of runoff which must be temporarily stored and treated would equal ten acre-inches or 36,300 cu. ft. To drain the entire amount (36,300 cu. ft.) in three days (72 hrs.) would require an average rate of outflow equal to 504 cu. ft./hour. The length (L) of underdrain needed to satisfy the three day requirement is:

$$L = \frac{Q}{KiW} = \frac{504 \text{ cu. ft./hr.}}{(.833 \text{ ft./hr.})(1)(3 \text{ ft.})}$$

$$L = \underline{202 \text{ ft.}}$$

However, let's suppose the detention area was also planned for use as open space such as a park or recreation facility. In this instance it would be desirable to discharge the stored water within a day. The length (L) needed to provide sufficient drawdown in 24 hours would be:

$$L = \frac{1513 \text{ cu. ft./hr.}}{(.833 \text{ ft./hr.})(1)(3 \text{ ft.})}$$

$$L = \underline{606 \text{ ft.}}$$

In either instance, the discharge capacity of the underdrain pipe must be equal to or greater than the flow intercepted (Q). Given the latter circumstances, the pipe should be sized to carry at least a flow equal to 1513 cu. ft./hr. Converting this value to 0.42 cfs., the pipe size may be determined in accordance with procedures mentioned earlier (see Part I). Using the SCS Drain Capacity Charts included in this section, 8" corrugated polyethylene pipe (CPEP) with a roughness coefficient (n = 0.015) at a grade of 0.5% or .005 ft./ft. would be capable of conducting the proper amount of water.

The results of this analysis are based on several simplifying assumptions that would rarely, if ever, occur. The hydraulic gradient (i), for example, does

not remain constant. The value will change as the water level in the facility rises and falls. A more detailed assessment procedure capable of ascertaining the difference in drainage capacity under variable head conditions would reduce the amount of drain required.

Likewise, the assessment also presumes there are no other contributions from sources such as groundwater. Artesian type conditions would be expected to occur should high water table elevations surround the treatment area during any portion of the year. The size of the underdrain pipe would need to be increased. An increase of 1.5 to 2 times should be used in these situations.

- b) A more complex method to determine if a specific design will satisfy the drawdown requirement under various head conditions is currently used by several engineering companies. The procedure combines Darcy's Law and the Falling Head Equation into a form similar to that used to determine the hydraulic conductivity (K) from falling head permeability testing techniques. The equations may be rearranged to solve for either drawdown time (t) or filter area (A) if the hydraulic conductivity (K) is known, and certain simplifying assumptions are made.

$$K = \frac{2.3 aL}{A dt} \text{ Log}_{10} \frac{h_0}{h_i}$$

$$dt = \frac{2.3 aL}{AK} \text{ Log} \frac{h_0}{h_i} \text{ and,}$$

$$A = \frac{2.3 aL}{Kdt} \text{ Log} \frac{h_0}{h_i}$$

In these equations a is the average cross-sectional area of the pond or reservoir; A is the cross-sectional area of the soil profile or filter served by the drain tube; L is the length or depth of the soil profile (filter media) through which the water must travel to reach the gravel envelope or perforated pipe; in most cases that value will be a minimum or two feet; and dt is the time interval (hrs.) during which the elevation drops from its initial value (h_0) to some lower value (h_i) as the water approaches the pond bottom.

Example: Assume our objective is to estimate the time to remove the 36,300 ft³ of runoff discussed in the previous problem. The area of the facility is assumed to remain constant as the water recedes. The head (h_0) at the time when the facility was full would equal 5.0 feet. The average area (a) may be calculated by dividing the pond volume by the depth. In this case presume the pond was designed 3 feet deep.

Working through the equation when the facility was full to determine the area (A) of filter needed:

$$\begin{aligned}a &= 12,100 \text{ square ft.} \\L &= 2.0 \text{ ft. (average length of travel)} \\K &= 10 \text{ in/hr. or } .833 \text{ ft. hr.} \\h_o &= 5.0 \text{ ft.} \\h_i &= 2.0 \text{ ft.} \\dt &= 24 \text{ hrs.}\end{aligned}$$

Therefore:

$$A = \frac{2.3 a L}{Kdt} \quad \text{Log} \quad \frac{h_o}{h_i}$$

$$A = \frac{2.3 (12,100)(2.0)}{.833 (24)} \quad \text{Log} \quad \frac{5.0}{2.0}$$

$$A = \frac{55,660}{20} \times 0.40$$

$$A = \underline{1,113 \text{ ft}^2}$$

Given no accretion from other sources, a filter three ft. wide by 371 ft. long should be capable of draining the facility. As may be seen, the results using this procedure will be much more favorable to the applicant since the drain length is reduced. This is because the previous assumption relative to a hydraulic gradient of unity ($i = 1$) is not used in this procedure. The procedure is much less conservative than the former.

The designer should also notice that this analysis is dependent on the presumption that the size and slope of the drain tube as well as the number and size of pipe orifices or openings will not restrict the maximum peak flow delivered to the drain tube via the filter media.

In using the equation above, pipe size must be checked using the pipe flow capacity charts mentioned previously. Likewise, orifice area must be checked using the orifice equation which may be written:

$$Q = C_d A (2gh)^{1/2}$$

Where:

- Q = Orifice discharge (cfs)
- C_d = Coefficient of discharge (usually assumed to be 0.6)
- A = Orifice cross-sectional area (ft.²)
- g = Gravitational acceleration (32.2 ft./sec.²)
- h = Hydraulic head above the orifice (ft.)

The maximum peak flow expected from the filter system must first be calculated once again using Darcy's Law.

$$Q = KiA = K \frac{Y}{D} A$$

Where:

K = Coefficient of soil permeability (ft./hr.)

i = $\frac{Y}{D}$ = Instantaneous hydraulic gradient

A = Area of trench or filter (ft.²)

Y = Head difference between water level elevation behind the structure at any point in time and the flow line of the underdrain pipe or top or gravel envelope if used

D = Depth of soil column or filter to flow line of underdrain or top of envelope material

Q = Instantaneous rate of discharge (ft.³/hr.)

Continuing to work through this example problem:

K = 0.83 ft./hr.

Y = 5.0 ft. (when the detention area is full)

D = 2.0 ft.

A = 1113 ft.²

Therefore:

$$\begin{aligned} Q_{\max} &= K \frac{Y}{D} A = 0.833(2.5)(1113) \\ &= 2318 \text{ ft.}^3/\text{hr.} \\ Q_{\max} &= 0.64 \text{ cfs.} \end{aligned}$$

Checking this rate of flow with the SCS pipe capacity charts mentioned previously for n = 0.015 and hydraulic grade (0.005 ft./ft.) indicates that an 8-inch pipe will remain adequate to handle the maximum peak flow.

The minimum orifice area required is then determined using the following equation:

$$A = \frac{Q}{C_d \sqrt{2gh}}$$

Where: A = total orifice area required

Q = .64 cfs

C_d = .6

g = 32.2 ft./sec.²

h = 5.0 ft.

$$A = \frac{.64}{.6 \sqrt{64.4 \times 5}} = .059 \text{ ft.}^2/371 \text{ ft. of pipe}$$

$$= 1.6 \times 10^{-4} \text{ ft.}^2/\text{ft. of pipe}$$

$$A = \underline{.023 \text{ in}^2 \text{ ft. of underdrain pipe}}$$

Therefore, a pipe is required that contains at least eight or more 1/16 inch diameter holes per foot.

2) Calculating the length of a bank filter and determining pipe size required.

Either of the two basic procedures discussed above may also be used to determine the length of a bank filter system. However, the designer should notice that both the cross-sectional area of the filter media intersected by the drain and the hydraulic gradient which was presumed to be unity or larger in the previous analysis decrease with time in these systems. These factors must be taken into account and act to complicate the more simplistic procedures discussed previously. The length of bank filters is usually established by trial and error. The designer chooses the underdrain length desired and subsequently checks drawdown time against state regulations or land use requirements until a suitable configuration is reached.

a) Procedure for sizing bank filters based on Darcy's Equation

The most simple and easily understood method for sizing bank filters is primarily applicable to conditions wherein lateral flow is predominant (see Figure 6-52).

Once again, the rate of flow should be in accordance with Darcy's Law which states that the flow velocity of water through porous media is proportional to the hydraulic conductivity and the hydraulic gradient. The relationship may be stated:

$$V = Ki$$

Where: V = velocity of flow

K = the hydraulic conductivity

i = the hydraulic gradient $\frac{\Delta Y}{\Delta D}$

Y = the change in elevation between the free water surface in the reservoir and a horizontal reference plane usually passing through the flow line of the underdrain pipe.

D = the horizontal distance from the edge of the free water surface to the vertical reference plane (usually chosen passing through the center of the underdrain pipe).

The flow of water delivered to the drain is equal to the velocity (K_i) as it moves through the media, multiplied by the cross sectional area (A) of the filter. Contrary to the more simplistic situations analyzed earlier, this area changes not only in relation to the depth of the free water surface but also decreases in relation to the upper line of seepage as it moves toward the underdrain.

Hence, Darcy's Law is usually applied in the design of bank filters in much the same way as it is for determining seepage through an embankment. The media is assumed to be homogenous throughout and located on an impervious foundation (e.g., the bottom and sides of filter trenches are presumed impermeable). Since the depth of the saturated zone varies as it approaches the drain, the mean width is used to calculate the area factor used in these determinations.

When the bottom of the filter and the horizontal reference plane coincide, (A) is assumed to equal one-half the vertical distance (H) shown in Figure 6-52 multiplied by the length of the filter (L). Stated in mathematical form:

$$A = \frac{H L}{2}$$

Where: A = Mean cross sectional area of the saturated zone (ft^2)
 H = Change in elevation or depth of the filter from the free water surface to the bottom of the filter (ft)
 L = Length of the filter (ft)

The instantaneous rate of discharge (Q) is subsequently calculated at the various stages of drawdown or storage elevations in the pond. The greater the number of increments the more accurate the assessment is likely to be.

The formula for expressing the discharge through a unit length of filter media for each increment is:

$$q = K \left(\frac{\Delta Y_n}{\Delta D_n} \right) \left(\frac{H_n}{2} \right)$$

When the elevation of the free water surface does not exceed the top of the filter, the value of (H_n) is equivalent to the change in elevation per increment of rise or fall in the storage area (i.e., $H_n = \Delta Y_n$). The equation subsequently may be written:

$$q = \frac{K}{2} \left(\frac{H_n^2}{\Delta D_n} \right)$$

Where: q = discharge rate per unit length
 K = hydraulic conductivity of the filter material comprising the least permeable section
 H_n = change in elevation from the flow line of the drain or other reference point to the water level in the reservoir
 D_n = horizontal distance measured from the edge of the free water surface to the vertical plane of reference (in this instance, the middle of the perforated pipe).

Values of (q) are multiplied by the total length (L) of the filter system to determine the total discharge capacity (Q) of the facility. In equation form the relationship may be stated:

$$Q = (q)(L)$$

In some situations, the bottom of the filter is located below the flow-line of the pipe. In these instances, the value of (H) will exceed (Y_n). The mean discharge area may be determined as follows:

$$A = \frac{(H - \Delta Y) + H}{2} L = (H - \frac{\Delta Y}{2})L$$

In either case, the instantaneous discharge is averaged between each increment. The drawdown time is then determined by dividing the volume of storage available in the reservoir between stages by the mean rate of outflow projected through the filter.

Similar to previous examples presented in this section, Table 6-15 shows how the drawdown time would be calculated for a project designed to treat approximately 36,300 ft³ or 10 acre inches of runoff. By comparison, it may be seen that bank filtration is not nearly as hydraulically efficient as a means of treatment as bottom filters or underdrains. Earlier it was shown that only 200 ft. of bottom filter would be needed to drain an equivalent amount of water within 72 hours. However, a 75% increase in length (350 ft.) of bank filter is required to accomplish the same task even though the hydraulic conductivity of the media is presumed to be more than five times greater than the earlier example.

The designer should be aware that the configuration of the system itself can have substantial influence on the hydraulic efficiency of these facilities. Most of these systems are relatively low head since they are normally designed with little more than 2 feet of elevation difference between the maximum stage in the facility and the bottom of the filter. Consequently, there is often only a very slight energy gradient to move water toward the drain. In such situations elongated envelopes (see Figure 6-53) are often used to provide higher internal gradients and improve the flow of water through these structures. The higher discharge capacity decreases the length of filter needed to satisfy drawdown requirements.

TABLE 6-15

Incremental Method for Calculating Drawdown Time for Bank Filters Using Darcy's Equation

Increment	Storage Vol. (ft ³)	Storage (ft ²)	Horizontal (1) Dist. "ΔB" (ft)	Change in Elev per (1) Increment "ΔV" (ft)	Hydraulic (2) Gradient "i" (ft/ft)	Hydraulic Conductivity "K" (ft/hr)	Avg Discharge (3) Area "A" (ft ²)	Instantaneous Discharge Q = KIA (ft ³ /hr)	Avg. Discharge (4) Per Increment "Q" (ft ³ /hr)	Drawdown Time (5) "t _d "/Increment (Hrs)
1	36,312	9,690	2.0	3.0	1.0	5.0	525	2625	2089.07	4.64
2	26,622	9,276	3.5	2.5	.71	5.0	437.5	1553.13	1126.57	8.23
3	17,346	8,871	5.0	2.0	.40	5.0	350	700.00	500.94	17.71
4	8,475	8,475	6.5	1.5	.23	5.0	262.5	301.88	207.82	40.78
5	0	36,312 TOTAL	8.0	1.0	.13	5.0	175	113.75		71.36 TOTAL

Notes: Pond with Top Length = 150'
 Top Width = 132'
 Depth 1/2" Storage = 2.0'
 Side Slopes 3:1
 Rectangular Shaped
 Assume 350' of filter is used (L = 350 ft)

(1) Values of D and Y are illustrated with Figure 6-52.

(2) Hydraulic Gradient $i = \frac{\Delta V}{\Delta B}$, i (Max) = 1.0

(3) Avg. "A" = $\frac{\Delta V \times L}{2}$

(4) Avg. Discharge Q' = $\frac{Q(t)}{t}$

(5) Drawdown time = $\frac{\text{Storage}}{Q}$

FIGURE 6-53

Elongated Gravel Envelope to Provide Improved Internal Gradient for Low Head Bank Filtration Systems

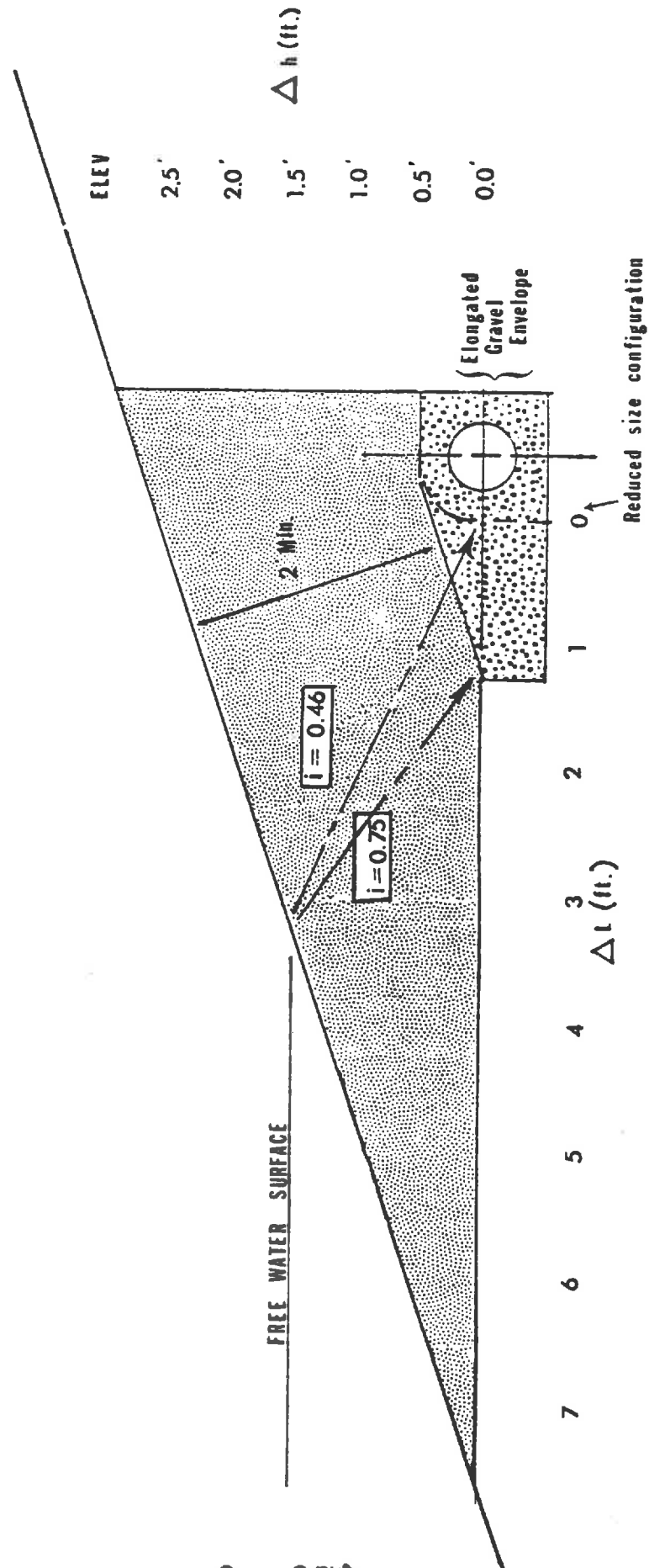

b) Flow Nets

Another commonly used method for evaluating problems related to seepage through porous media involves the construction of flow nets. This type of analysis can also prove to be a valuable tool for the design of stormwater filtration systems. A diagram of a flow net constructed for a rather commonly used bank filter design is illustrated in Figure 6-54. Those interested in developing skills in flow net analyses for this and other configurations of bank filters may find Seepage, Drainage, and Flow Nets by H.R. Cedergren to be a valuable reference.

Flow nets may be applied in sizing a bank filter in the same manner as Darcy's Law was used earlier. A number of diagrams are constructed, each correlating to various stages within the reservoir. The individual diagrams are then used to determine the discharge relationship per linear foot of filter. The flow net equation may be written:

$$q = KH \frac{nf}{nd}$$

Where: q = seepage quantity ($L^3/T/ft.$ of filter)
 K = permeability of the media (L/T)
 H = net head (L) as illustrated in Figure 6-54
 nf = number of flow channels
 nd = number of equipotential drops

The ratio nf/nd is otherwise known as the shape factor. As noted by Cedergren, the number of flow channels and the corresponding number of equipotential spaces depends on the shape of the cross section, and will not necessarily be a whole number. A different shape will produce a different number of spaces and channels. He goes on to warn those who are just learning by stating that novices "sometimes overlook one or more of the basic rules. The resulting flow net can be so filled with errors that a grossly distorted picture of a seepage pattern will be given". However, he also points out that any number of flow nets for a given problem will agree when the work has been done correctly. There is but one solution to a given problem. Consequently, although this work may be quite cumbersome at first, once flow nets have been constructed for a given configuration of filter they will continue to apply to the specific design or shape as long as they are not changed.

Once the unit rate of discharge (q) is established at each increment of drawdown the total stage discharge relationship may be determined by multiplying the value of (q) at each stage by the length of the filter (L). The instantaneous discharge Q is averaged between each increment. Assuming the volume of storage between increments is known, the drawdown time (t) may be calculated by dividing the volume by the average rate of outflow in the same manner as illustrated in Table 6-15. Here again, the preparation of such a table is an aid to any reviewing agency and can help speed up project approval. Preliminary evaluations seem to show that flow net analyses may

FIGURE 6-54

Flow Net Diagram Illustrating Lines of Seepage Through a Typical Bank Filtration System

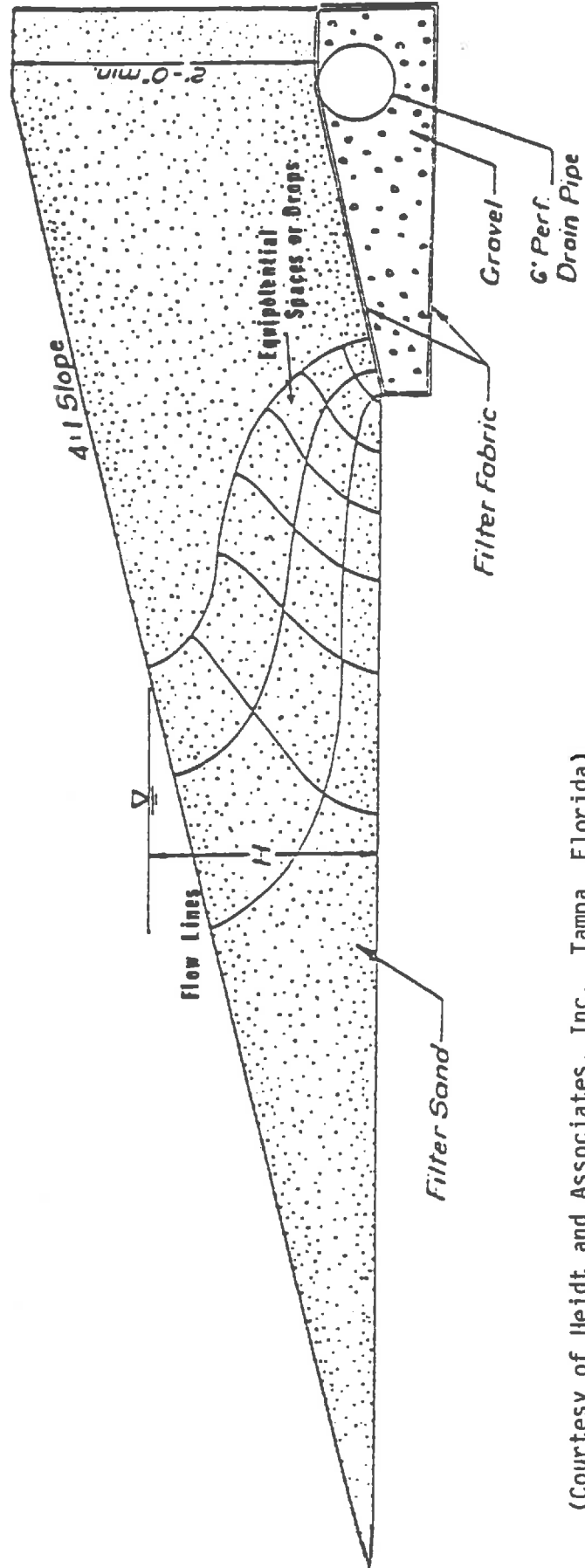

(Courtesy of Heidt and Associates, Inc., Tampa, Florida)

(Not to scale, for illustration only)

offer benefits over the procedure described in section 2(a) when gradients of 100% or more are likely to occur over much of each filtration cycle.

c. Other Analytic Approaches

Currently several other methodologies being used to design underdrains that are not incremental in nature. In these instances several designers have modified the designs illustrated previously. This has enabled the use of equations in which drawdown time (t) or filter length (L) may be calculated in one step based on a single formula. Figure 6-55 illustrates the general design and important dimensions of two such systems.

The form of the expression used to estimate the length of filter trench (L) required to accomplish drawdown in the time desired is written as follows:

$$L = \frac{1.33 A_r D}{KtW} \ln (Y_1/Y_2) \text{ for system (a), and;}$$

$$L = \frac{A_r D}{KtW} \ln (Y_1/Y_2) \text{ for system (b) Figure 6-55.}$$

A_r = Average area of reservoir between elevation Y_1 and Y_2 (ft²)

Where: L = length of filter required (ft)
K = hydraulic conductivity of the filter media (ft/hr)
t = allotted drawdown time (hrs)
W = trench width as illustrated in Figure 6-55 (ft)
D = average distance which water must travel through the filter profile as shown in Figure 6-55 (ft)
 Y_1 = Difference in elevation between the flow-line of the underdrain pipe and the water level in the reservoir at the appropriate volume of storage (ft)
 Y_2 = Difference in elevation between the flow-line of the underdrain and the stage in the reservoir following discharge of the treatment volume required (ft)

It should be noted that the mean distance (D) traveled is used for calculations involving systems similar to that illustrated in Figure 6-55(a) while for the system shown in Figure 6-55(b) the distance is equal to 2.0 feet. However, the difference in the form of each equation is primarily due to differences in the magnitude of the cross section visualized to be intersected by the drain in each situation. In Figure 6-55(b) the trench is perpendicular to the face of the bank. Flow through the filter, toward the drain is predominantly vertical. The entire cross-section or width (W) of the filter is intersected by the drain and its surrounding gravel envelope. Flow is primarily normal to the plane of reference. In these circumstances, the discharge area remains relatively constant as water moves toward the drain. The phreatic surface will be parallel to the upper trench wall, intersecting nearly the entire width of the drain before curving toward the drain tube itself. The presumption that $A = WL$ is primarily correct in this circumstance.

(a) Reduced Head System

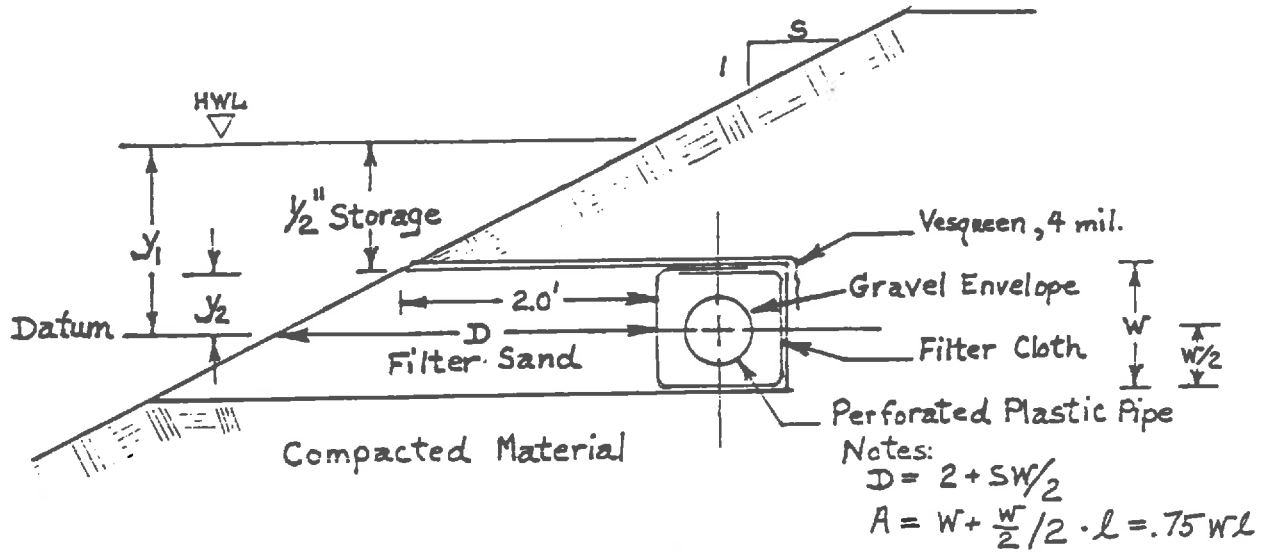

(b) Side-of-the-Bank System

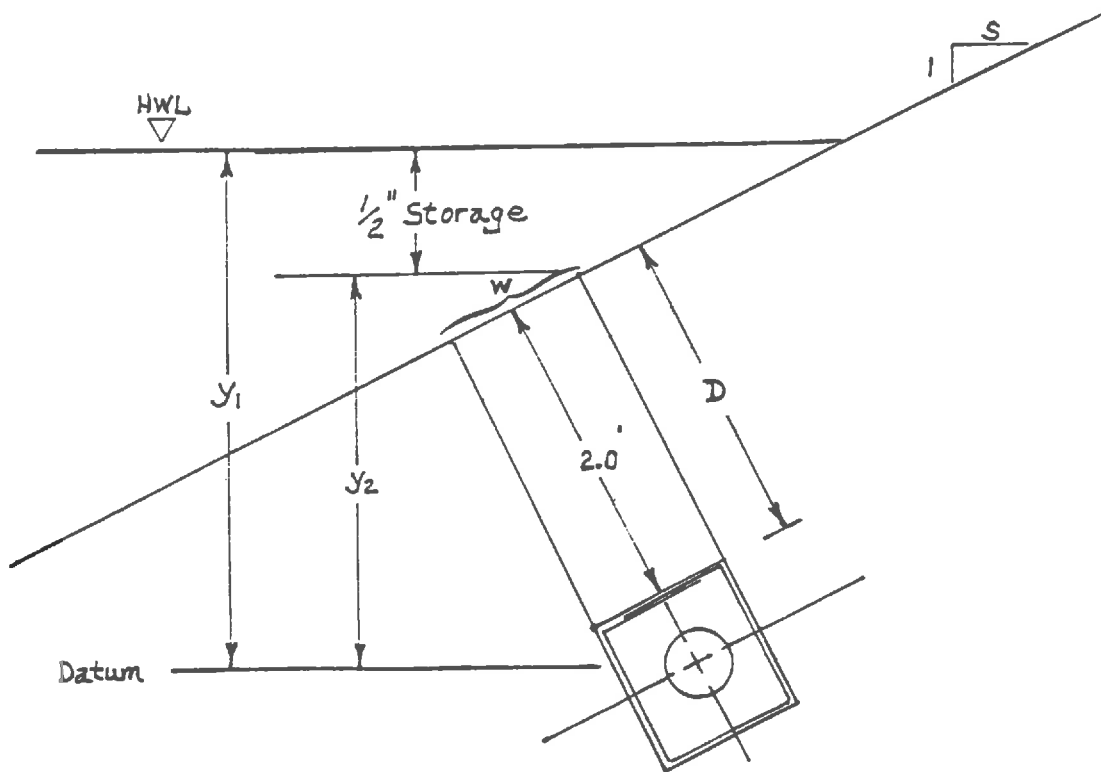

FIGURE 6-55

Sketch of Bank Filter Designs Illustrating Symbols for Use With Single Step Evaluation of Trench Length and Drawdown Time

(Courtesy of Post, Buckley, Schuh and Jernigan Engineers, Clearwater, Florida)

On the other hand, this assumption does not pertain in the horizontal flow situation shown in Figure 6-55(a). The reference plane (passing through the flow line of the pipe when full flow is assumed) does not intersect the entire cross-section or width of the filter. Flow is primarily parallel to the plane of reference. In these circumstances the width of the saturated zones is reduced as water moves toward the drain. The average discharge area (see notation with figure) should be used in this situation. The presumption that the discharge area (A) is equal to the entire width (W) of the drain times its length (L) would be correct only in the event that the water level was expected to be at the top of the trench during operation. This assumption is pertinent to submerged drains only. The latter situation would not be recommended because of added difficulties in the design, installation, operation and maintenance of these systems due to constant anaerobic conditions.

When the length of the system is known, the equations may be rearranged to solve for the drawdown time associated with the system as follows:

$$t = \frac{1.33 \text{ Ar D}}{K \text{ W L}} \ln Y_1/Y_2 \text{ for system (a)}$$

$$t = \frac{\text{Ar D}}{K \text{ W L}} \ln Y_1/Y_2 \text{ for system (b)}$$

Similar to using other forms of Darcy's Law when the length and drawdown constraints are predetermined, the equation may be used to establish the required permeability. In this instance the designer would establish a trial thickness of the filter and calculate the hydraulic conductivity needed to satisfy these requirements. Likewise, the designer may select one or more permeabilities that represent commercially available filter materials within acceptable degrees of uniformity and effective size (as outlined in 17-25.025(2) F.A.C.) and calculate their required thickness.

3) Other Design Considerations

a) Pipe Size, Orifice Area, and Filter Cloth

The design procedures discussed in section 1 and 2 of this BMP are all primarily associated with the capability of the filter media to transmit water. The permeability associated with filter cloth (when used), the size and number of orifices or perforations in the drain pipe, and the capacity of the pipe itself can also limit the rate of discharge. Each of these factors must be checked as described in section 1(a) and (b) of the design criteria to also ensure that these factors will not effect drain requirements.

b) Safety Factors

Permeability is crucial to all of the design procedures. However, as noted by Cedergren, "Permeability can vary so widely that its physical significance is often difficult to comprehend,..." In this instance, the author was referring

to the differences in the properties of various aggregates (sand, clay, gravel, etc). However, tests of similar types of materials show that even these percolation rates may vary by 100% or more. In the light of the large margin of discrepancy associated with most design techniques and test results, safety factors on the order of at least two are appropriate. Drawdown time on the order of one-half of what is required should be encouraged.

c) Pollution Control

Filters for stormwater treatment are designed to remove particulates and their associated pollutants from the runoff waters as they percolate through the fine textured aggregate on its way to the drain tube. According to preliminary indications based on information published by Dr. Y.H. Chen et.al (1981) "a layer of soil can stop the passage of a particle if the size of this particle is larger than one-fifth of the size of particles establishing the soil layer". Using the effective size (D_{10}) requirements specified for filters in Chapter 17-25 F.A.C. it is expected that particles on the order of .04 to .10 mm. may be removed. According to grain size distribution data for pollutants associated with street surface contaminants (Sartor and Boyd, 1972), more than 90% of the suspended and oxygen demanding materials found in urban stormwater should be removed. Preliminary information reported from an in-line filter system installed on a tributary to Lake Jackson near Tallahassee supports this conclusion.

Soluble pollutants are not removed so readily. However, in general, the more fine textured the media, the better the pollutant removal expected. When designing a filter system, these considerations, as well as, the form of contaminants to be removed from the stormwater, should be balanced with the improved hydraulic capacities which are concomittent with more coarse grained, even-graded filter media.

d) Filter Fabric and Piping Control

Filter cloth must also contain pore spaces which will not permit the filter media (sand) to be carried away by the water. The Corps of Engineers and Yung Hal Chen, Daryl B. Simons, and Phillip M. Demery in "Hydraulic Testing of Plastic Filter Fabrics" discuss valuable information pertaining to the proper selection of these materials. Several important guidelines are summarized as below:

- 1) In order for filter fabric to work as a permeable constraint to stop adjacent particles of filter material from washing through the fabric, the EOS (equivalent opening size of the fabric) divided by the D_{85} of the sand should be less than or equal to two.

$$EOS/D_{85} \leq 2$$

- 2) To avoid clogging by fine particles requires that the EOS of the fabric must be equal to or greater than twice the D_{15} of the filter material.

$$EOS \geq 2D_{15}$$

Planning an Underdrain or Filter System

Analyzing Information and Data from Surveys and Investigations

In most humid areas, many years of experience with subsurface drainage installation have provided the main basis for determining drainage requirements for various soil types and problem areas. Special investigations are necessary for drainage of soils where experience is lacking. One of the most important phases of planning either an underdrain or stormwater filtration system is to compile and analyze the field data collected through various surveys, investigations and studies. These investigations are difficult because subsoil and groundwater conditions are not evident through visual inspection. Various methods and techniques have been developed whereby these conditions can be determined and made evident through a graphical or statistical presentation. The following is a discussion of some of the methods and procedures commonly used.

- 1) Water Table Contour Maps - The elevation of the water table at selected points covering the area are plotted on the base map. By interpolation and extrapolation lines of equal water table elevation are drawn. The completed map represents the surface configuration of the water table at a specific time.

To be of greatest use as a tool in planning, groundwater contour maps should be superimposed on topographic maps to give the relationship between surface configuration and water table configuration. An example of this type of map is shown in Figure 6-56. The completed map will show areal delineation of depth to groundwater which is usually the criteria for determining maximum allowable depth of stormwater filters.

- 2) Observation Well Hydrographs - On profile paper, cross-section paper or printed hydrograph sheets, plot water table elevation against time. Well hydrographs may be compiled for all observation wells or for a few selected wells at key locations. The time scale, which is usually on the abscissa (horizontal), is in days by months for one year's time. The ordinate (vertical) is used for water table elevation and is in feet and tenths. The completed hydrograph shows water table fluctuation by seasons: the high level and the low level for the season.

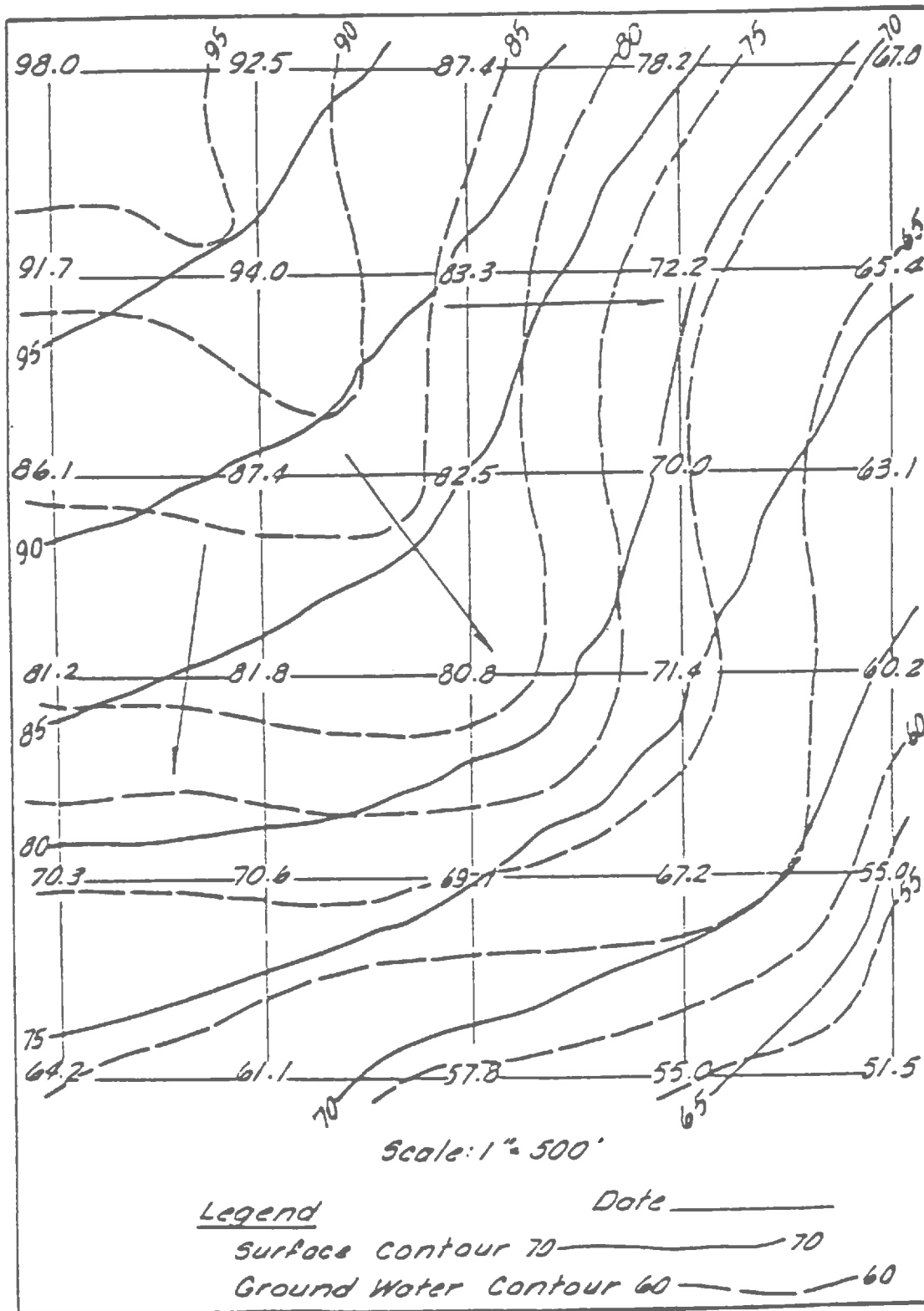

FIGURE 6-56

Typical Water Table Contour Map

It is often very helpful in determining the source of groundwater.

Even when compiled from wells not exactly located on the immediate grounds, this data may aid in the interpretation of more short term instantaneous water table elevation mapping information. Knowledge related to seasonal fluctuations of high water table conditions can help prevent the under design and consequential bypassing of these stormwater treatment systems due to an influx of water not normally expected to occur and left unaccounted for in drain size analyses.

- 3) Profile Flow Patterns - Profile flow patterns may be shown by plotting the surface of the ground, information on subsoil materials, and hydraulic-head values at points where measurements have been made with piezometers. Lines should be drawn to connect points of equal hydraulic head. Convenient hydraulic-head intervals may be selected extending over the range of measured values for hydraulic head. Usually an interval is selected that allows a number of equal hydraulic-head lines to be sketched on the same profile. The component of flow in the plane of the profile is normal to lines of equal hydraulic head if the profile section is plotted on a one to one scale. Using this scale, flow lines can be sketched in at right angles to the equal hydraulic-head lines, with arrows to show the direction of flow.

A vertical component of flow is indicated where the hydraulic-head changes. This component may be either up or down. Profile flow patterns are very helpful in detecting artesian conditions, which is particularly an important consideration in determining the size, shape, and spacing of laterals in underdrain system design.

- 4) Gradation and Permeability Tests Results - Mechanical analysis (sieve size) is important for both filter and underdrain design. The results of tests run on the soils to be underdrained or the sand or other fine textured aggregate used for filtration are recorded and plotted on a grain size distribution chart as illustrated in Figure 6-57. Shown on the vertical scale at the left of the graph is the percentage of a soil or sand sample passing each of a number of increasingly smaller (in opening size) screens or sieves. A curved line connecting the points is shown for easy interpretation of percentages related to sizes in between the size separates.

This data is subsequently used to verify that the filter media conforms to state requirements listed in Section 17-25.025(2) pertaining to effective size and coefficient of uniformity. In both underdrain and filter design such information is also useful to help evaluate the capacity of a given configuration and to avoid potential piping of the filter sand or soil into the drain.

FIGURE 6-57

Typical Grain Size Distribution Chart

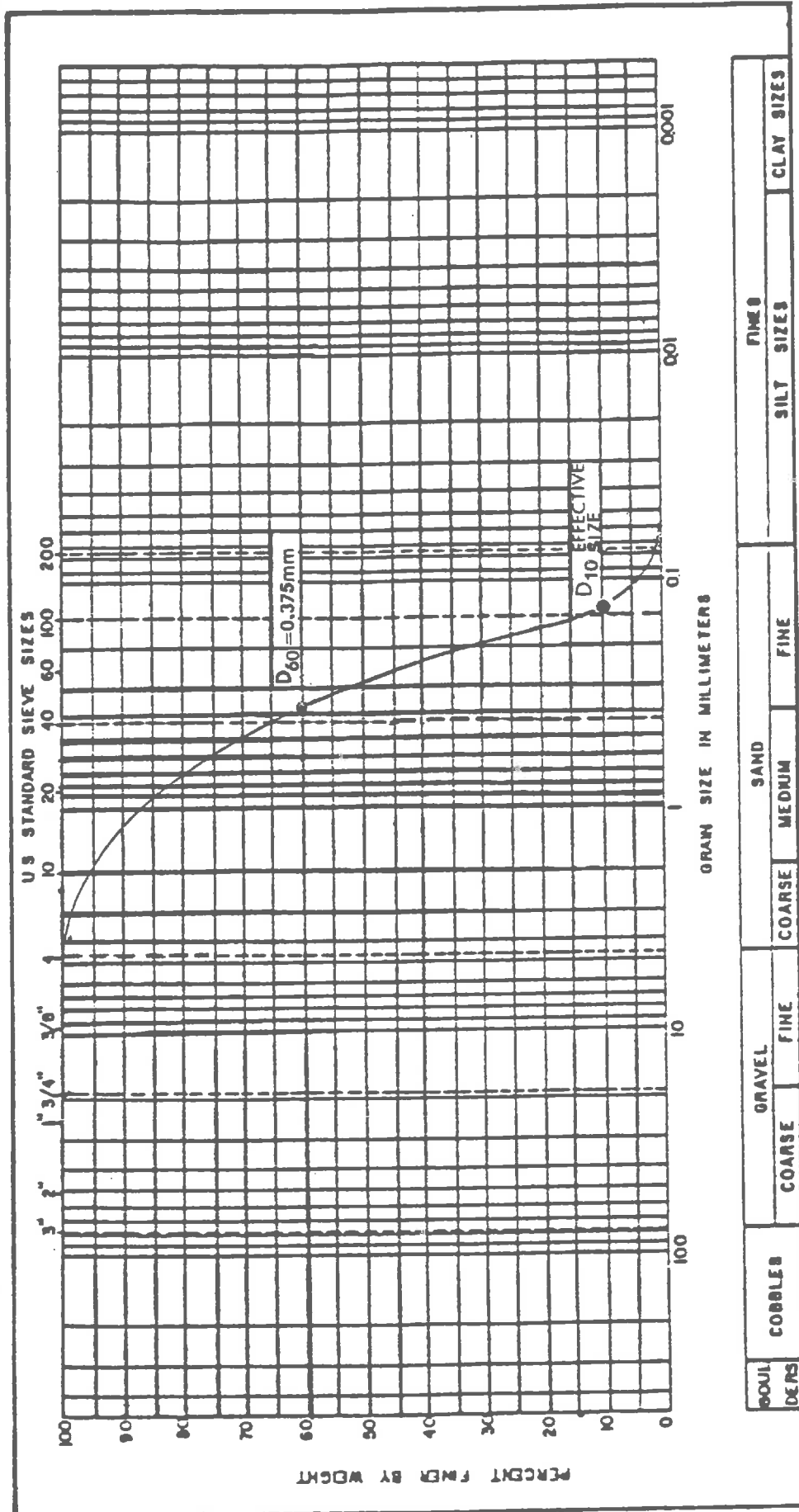

Sample 1: Light tan, fine-medium quartz sand

D10 = 0.15

Cu = 2.5 (D60/D10)

Likewise, information pertinent to the capacity of a particular soil or filter sand to conduct or transmit water is quite important. There are a number of ways in which the permeability rate may be determined. Discussions of the applicable techniques are included in most soil mechanics texts. In this manual several of the more common field testing procedures are discussed in more detail in Appendix 6-2. Field testing is usually preferred for underdrain design while laboratory methods are most often used for establishing the hydraulic conductivity (K) of filter media.

Salt-water Intrusion in Coastal Areas

When planning a filter or underdrain design system in areas in close proximity to sea coasts, certain precautions must be considered in regard to salt-water intrusion. Beneath coastal areas, the normal movement of fresh ground water toward the sea usually prevents landward intrusion of the denser sea water; however, pumped well drains or pumped surface and subsurface drainage can reverse this situation. If this happens, the consequences can be serious since land once subjected to salt-water intrusion is difficult to reclaim.

Guidelines for Prevention - In coastal areas salt-water is present in underground strata at a depth equal to about forty times the height of fresh water above sea level. This is given by the Ghyben-Herzberg relation.

This relationship is only approximate because the density of sea water varies with temperature and the salts present. However, the ratio of 40.0 to 1.0 is adequate, as a general rule, for the purposes discussed here. In coastal areas, lowering of the water table one foot will cause a 40-foot rise in the fresh water-salt water interface. Lowering of the water table to mean sea level will bring the interface up to mean sea level which will in most cases render the land salty and unfit for many uses.

As a general guide for use in planning pumped stormwater systems near the coast, sumps should not extend below mean sea level. Filters and underdrains should be designed and developed for minimum drawdown of the water table and be located so that drawdown is distributed as widely as possible and not concentrated in specific areas.

Outlets for Underdrains and Filters - An outlet for the stormwater system must be available for gravity flow or by pumping. The outlet must be adequate for the quantity and quality of the effluent to be disposed of without causing damage to other areas and with minimum deterioration of the water quality in the outlet.

An open-ditch outlet for gravity flow from a buried drain should permit discharge from the drain above the elevation of normal flow in the outlet. Interruption of flow from the drain due to storm runoff in the outlet should

not occur so often and with such duration that the rate of drawdown by the buried drain would fail to meet the design requirements specified in Chapter 17-25 F.A.C. during most situations.

Construction and Materials Specifications for Underdrains and Stormwater Filtration Facilities

General

The location of the main drain and laterals should be planned to obtain the most efficient and economical drainage system. A few general rules to follow are:

- 1) Provide the minimum number of outlets.
- 2) When practical lay out the system with a short main and long laterals.
- 3) Orient the laterals to use the available slope to the best advantage.
- 4) Follow the general direction of natural waterways with mains and submains.
- 5) Avoid locations that result in excessive cut.
- 6) Avoid crossing waterways wherever feasible. If waterways must be crossed, use as near a right-angle crossing as the situation will permit.
- 7) Where feasible, avoid soil conditions that increase installation and maintenance cost.

Laterals should be located in the direction for the most effective collection of excess water, with due regard to the grade required for prevention of sedimentation, and following the rule of long laterals with short mains where feasible. Where it is desirable for main drains to be located parallel to a ditch deeper than the drain, enough distance should be maintained between ditch and drain to prevent washouts in the drain. Submains may be used to eliminate crossing waterways and to reduce the number of lateral connections to the main.

Inspection and Handling of Materials

Material for drains shall be given a rigid inspection before installation. Bituminized fiber and plastic pipe and tubing shall be protected from hazards causing deformation or warping. All material shall be satisfactory for its intended use and shall meet applicable specifications and requirements.

Placement and Coarse Aggregate Bedding Requirements

All drains, both flexible as plastic tubing and non-flexible as clay and concrete tile, shall be laid to line and grade and covered with approved blinding, or filter material. A minimum 3-inch thick gravel envelope wrapped in filter cloth is suggested to improve flow into the drain. Either of the two methods below may be used.

- 1) Except as provided in Method 2 below, the bottom of the excavated trench shall be shaped or grooved. Flexible type drains, when placed, shall be embedded in undisturbed soil for approximately 60 degrees of their circumference. After placement of all types of drains, friable material taken from the trench spoil or cut from the trench side walls shall be placed around the drain in such a manner that it will completely surround and support the drain and fill the trench to a depth of 3 inches over the top of the drain. To be suitable, materials surrounding the drain must contain no hard clods, rocks, or fine materials which would cause a silting hazard in the drain.
- 2) When special shaping or grooving of the trench bottom is not provided to embed the drain when placed, the drain shall be laid directly upon the envelope material. A sufficient quantity shall be used to fill the trench to a depth of 3 inches surrounding the drain. Envelope material shall consist of coarse material, all of which shall pass a one and one-half inch sieve. FDOT No. 57 or equivalent is recommended. The material should be washed and contain no more than 1% silt, clay or organic matter. The aggregate should be hard, durable, and comply with the requirements for soundness specified in ASTM D-694-62. This provision is to determine that the aggregate is not susceptible to disintegration by water. The loss when subject to the Los Angeles abrasion test should not exceed 40%. Pre-Cenozoic limestones, dolomites, nor stone containing phosphate shall not be used.

The gap between tile or other drain pipe joints shall not exceed 1/4-inch for mineral soils or one-half inch for organic soils. Openings wider than these, occurring on the outer side of a curve in a tile line or due to tile irregularity, shall be permitted if they are covered with broken tile, fiber glass, or other suitable material.

The upper end of each drain line shall be capped with concrete or other durable material unless connected to a clean out structure or other facility.

Earth backfill or filter material shall be placed in the trench in such a manner that displacement of the drain will not occur after backfilling.

No reversals in grade of the conduit shall be permitted.

Where the conduit is to be laid in a rock trench, or where rock is exposed at the bottom of the trench, the rock shall be removed below grade enough that the trench may be backfilled, compacted, and bedded; and when completed, the conduit shall be not less than 3 inches from rock.

Alignment

When change in horizontal alignment is required, one of the following methods should be used to minimize head losses in the line:

- 1) Use of manufactured fittings, such as ells, T's, and Y's.
- 2) Use of a gradual curve of the drain trench to prevent excessive gap-space.
- 3) Use of junction boxes or manholes where more than two mains or laterals join.

Connections

Manufactured connections or junctions for joining two lines should be used. It is good practice to lay a submain parallel to a large tile main (usually 10 inches or larger) to prevent tapping the large main for each lateral. Tapping a large tile is difficult, costly, and is frequently the cause of failure. Savings, through the elimination of large connections, usually will offset the extra cost of a submain. Smooth curves in tile lines and manufactured tile connections or junctions of less than 90° have been recommended in the past on the assumption that energy losses at the junction of tile lines would be reduced. Investigations show that the variation in energy loss for different angles of entry are insignificant from a practical standpoint when the main and lateral are of the same size and the drains are flowing full.

Loads on Drains

General

Drains installed in the ground must have sufficient strength to withstand the loads placed upon them. In underdrains, the load which usually governs the strength required is the weight of the earth covering the drain. The magnitude of the load which the drain can safely support depends upon the unit weight of the soil, or sand, the width and depth of the trench, and the method of bedding and installation of the drain. Where the drain is at shallow depths (3 feet or less) there is danger from impact loads from heavy equipment. All installations should be checked to ensure adequate loadbearing strength.

Frequently drain installations are made in wide trenches and at greater depths than is possible with the average trenching machine. Draglines, backhoes, and other equipment may be used for deep trenches. Trenches excavated by this equipment are wide and the greater loads to be placed upon the drain must be determined so that a drain of adequate strength may be selected.

Underground Conduits

Research on loads on underground conduits (including tile) has been carried on by Marston, Schlick and Spangler at Iowa State University. The results of their work are used in determining the loads on underground conduits and their supporting strength. Information regarding loads on conduits may be found in the following publications.

"The Structural Design of Underground Conduits," SCS Engineering Division, Technical Release No. 5.

Engineering Handbook, Section 6, "Structural Design," U.S. Department of Agriculture, Soil Conservation Service.

"Soil Engineering," by Merlin Grant Spangler, International Textbook Company, Scranton, Pennsylvania.

"Design Data - Loads and Supporting Strengths," American Concrete Pipe Association, Arlington, Virginia.

"Handbook of Drainage and Construction Products," Armco Drainage and Metal Products, Inc., Middletown, Ohio.

Classification of Conduits as to Rigidity

Conduits used for subsurface drains may be of several kinds of materials. One characteristic of these various conduits important in determining the load-bearing strength is the degree of flexibility. Two classes of conduits according to their flexibility are as follows:

- 1) Rigid conduits, such as concrete or clay, fail by rupture of the pipe walls. Their principal load supporting ability lies in the inherent strength or stiffness of the pipe.
- 2) Flexible conduits, such as corrugated metal pipes and certain types of plastic pipe, fail by deflection. Flexible conduits rely only partly on their inherent strength to resist external loads. When the pipe deflects the horizontal diameter increases which compresses the soil at the sides and thereby builds up passive resistance which in turn helps support the vertically applied load.

Bedding Conditions for Rigid Ditch Conduits

The supporting strength of a conduit will vary with bedding conditions. Two types of bedding are generally used in drainage work and each has a load factor which, when multiplied by the three-edge bearing strength, will give the safe supporting strength of the conduit.

- 1) Impermissible bedding is that method of bedding a ditch conduit in which little or no care is given to shape the foundation to fit the lower part of the conduit or to refill all the spaces under and around the conduit with granular material. The load factor for this type of installation is 1.1.
- 2) Ordinary Bedding is that method of bedding a ditch conduit in which the conduit is bedded with ordinary care in an earth foundation shaped to fit the lower part of the conduit for a width of at least 50% of the conduit breadth, and in which the remainder of the conduit is surrounded to a height of at least 0.5 foot above its top by granular materials that are shovel-placed and shovel-tamped to completely fill all spaces under and adjacent to the conduit. The load factor for this type of installation is 1.5.

When sand and gravel filter or envelopes are used, the foundation need not be shaped since the filter and envelope material are placed entirely around the conduit and provide for lateral pressures on the conduit. With this type of installation the supporting strength of the conduit is increased above the three-edge bearing strength. Depending on its gradation and the care used in placing the sand-gravel filter or envelope, the load factor will be in the range of 1.2 for a poorly graded envelope of irregular thickness to 1.5 for a well-graded material of uniform thickness around the drain. To be effective the gravel envelope should have a minimum thickness of 3 inches.

Bedding Conditions for Flexible Drainage Tubing

A flexible conduit has relatively little inherent load-bearing strength, and its ability to support soil loadings in a trench must be derived from pressures induced as the sides of the conduit deflect and move against the soil. This ability of a flexible conduit to deform and use the soil pressure to support it is the main reason that light-weight plastic drainage tubing can support soil loadings imposed in drainage trenches.

A flexible tubing must be installed in a trench in a way which insures good soil support from all sides. There must be no voids remaining which would permit the soil pressure from backfill to cause deflection of the tubing to the point of buckling. Most installations will be made with machinery, without requiring a man in the trench to position the tubing or place the bedding. Some modification of machinery designed for installation of rigid

conduits usually is necessary to install flexible conduits efficiently. See the section on installation of corrugated plastic drainage tubing.

Drain Grades and Velocities

Underdrains and filters are placed at rather uniform depths, therefore, the topography of the land may dictate the range of grades available. There is often an opportunity, however, to orient the drains within the site in order to obtain a desirable grade. The selected grades should, if possible, be sufficient to result in a nonsilting velocity which experience has shown is about 1.4 feet per second.

The recommended minimum grades are as follows:

	<u>Precent</u>
4" drain	.10
5" drain	.07
6" drain	.05

On sites where topographic conditions require the use of drains on steep grades which will result in velocities greater than shown in the following table, special measures should be used to protect the line from undermining.

Maximum Permissible Velocity in Drains Without Protective Measures

<u>Soil Texture</u>	<u>Velocity-ft./sec.</u>
Sand and Sandy Loam	3.5
Silt and Silt Loam	5.0
Silty Clay Loam	6.0
Clay and Clay Loam	7.0
Coarse Sand or Gravel	9.0

The protective measures may include one or more of the following:

- 1) Use only drains that are uniform in size and shape and with smooth ends.
- 2) Lay the drains so as to secure a tight fit with the inside diameter of one section matching that of the adjoining sections.
- 3) Wrap open joints with tar impregnated paper, burlap, or special filter material such as plastic or fiberglass fabrics.
- 4) Select the least erodible soil available for blinding.
- 5) Use long sections of perforated pipe or tubing. (Bituminized fiber, plastic, asbestos cement, etc.).

Materials for Drains

"Drains" include conduits of clay, concrete, bituminized fiber, metal, plastic, or other materials of acceptable quality.

The conduit shall meet strength and durability requirements of the site. Current specifications as listed below or as included in the specifications guide shall be used in determining the quality of the conduit.

The following specifications cover the products currently acceptable for use as drains or for use in determining quality of materials used in drainage installations: (Source USDA, SCS-FL).

<u>Type</u>	<u>Specification</u>
Clay drain tile	ASTM ¹ C 4
Clay drain tile, perforated	ASTM C 498
Clay sewer pipe, standard strength	ASTM C 13
Clay pipe, extra strength	ASTM C 200
Clay pipe, perforated, standard and extra strength	ASTM C 211
Clay pipe, testing	ASTM C 301
Concrete drain tile	ASTM C 412
Concrete pipe for irrigation or drainage	ASTM C 118
Concrete pipe or tile, determining physical properties of	ASTM C 497
Concrete sewer, storm drain, and culvert pipe	ASTM C 14
Reinforced concrete culvert, storm drain, and sewer pipe	ASTM C 76
Perforated concrete pipe	ASTM C 444
Portland Cement	ASTM C 150
Asbestos-cement nonpressure sewer pipe	ASTM C 428
Asbestos-cement perforated underdrain pipe	ASTM C 508
Asbestos-cement pipe, testing	ASTM C 500
Bituminized fiber, perforated drainage pipe	Federal Spec. ² SS-P-358a
Homogeneous perforated bituminized fiber pipe for general drainage	ASTM D 2311
Homogeneous bituminized fiber pipe, testing	ASTM D 2314
Laminated-wall bituminized fiber perforated pipe for agricultural, land, and general drainage	ASTM D 2417
Laminated-wall bituminized fiber pipe, physical testing of	ASTM D 2315
Plastic drain and sewer pipe, styrene rubber	Commercial Standard ² CS-228
Perforations, if needed, are to be as specified in Fed. Spec. SS-P-358a	
Corrugated Polyethylene Pipe	
Small diameter through 6"	ASTM F 405
Large diameter through 24"	ASTM F 667
Pipe, corrugated, aluminum alloy	Federal Spec. WW-P-402a
Pipe, corrugated, iron or steel, zinc coated	Federal Spec. WW-P-00405

Clay Tile - These specifications may be modified as follows: the freezing and thawing and absorption tests may be modified or waived.

Corrugated Polyethylene Pipe - SCS standards and specifications for perforated corrugated plastic pipe may be found under standard 606.

¹American Society for Testing and Materials, 1916 Race Street, Philadelphia, Pa. 19103

²Superintendent of Documents, U.S. Government Printing Office, Washington, D.C. 20402

Other Clay and Concrete Pipe

Bell and spigot, tongue and groove, and other pipe which meets the strength, absorption, and other requirements of clay or concrete tile as covered above, except for minor imperfections in the bell, the spigot tongue or the groove, and ordinarily classed by the industry as "seconds," may be used for drainage conduits provided the pipe is otherwise adequate for the job.

Foundation Requirements

Soft or yielding foundations shall be stabilized where required and lines protected from settlement by adding gravel or other material to the trench, placing the conduit on plank or other rigid supports, or using long sections of perforated or watertight pipe.

Envelopes and Envelope Material

Envelopes shall be used around drains where required for proper bedding of the conduit, or where necessary to improve the characteristics of flow of groundwater into the conduit.

Materials used for envelopes do not need to meet the gradation requirements of filters, but they shall not contain materials which will cause an accumulation of sediment in the conduit or render the envelope unsuitable for bedding of the conduit.

Auxiliary Structures and Drain Protection

The outlet shall be protected against erosion and undermining of the drain, against damaging periods of submergence, and against entry of rodents or other animals into the drain as shown in Figure 6-58. A continuous section of pipe without open joints or perforations (Figure 6-59) shall be used at the outlet end of the line and shall outlet above the normal elevation of flow in the outlet ditch.

The pipe and its installation shall conform to the following requirements:

- 1) Where there is a hazard of burning to vegetation on the outlet ditch bank, the material from which the outlet pipe is fabricated shall be fire resistant. Where the hazard of burning is high, the outlet pipe shall be fireproof.
- 2) Two-thirds of the pipe shall be buried in the ditch bank and the cantilevered section shall extend beyond the toe of the ditch side slope or the side slope shall be protected from erosion. The minimum length of pipe shall be eight feet.

FIGURE 6-58

Rodent Protection for Outlet Pipe

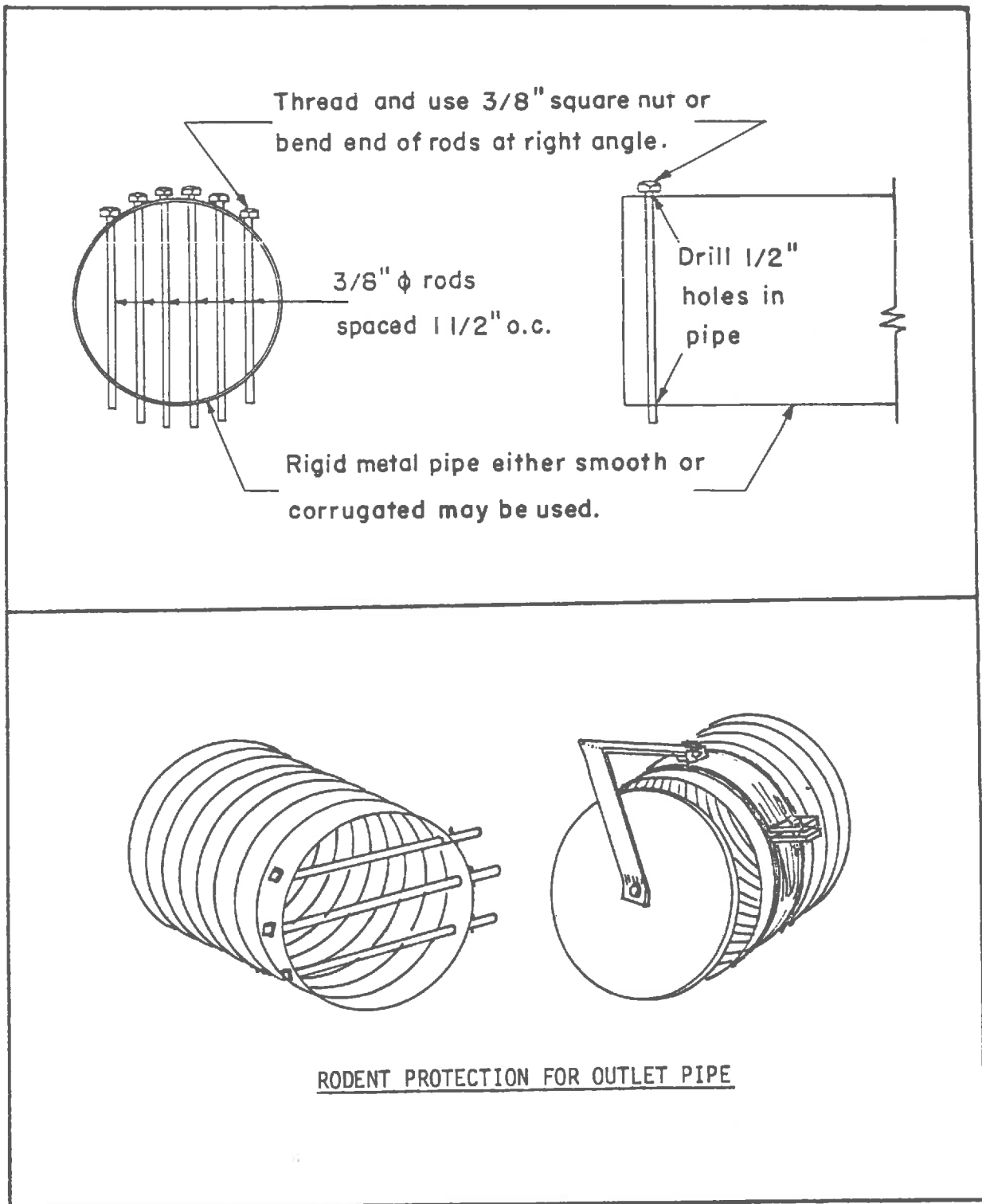

Source: USDA-SCS-FL

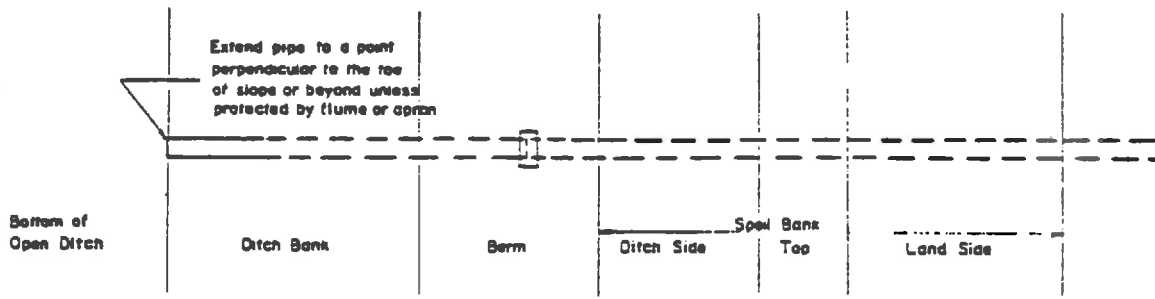

PLAN

Scale: 1" = 5'

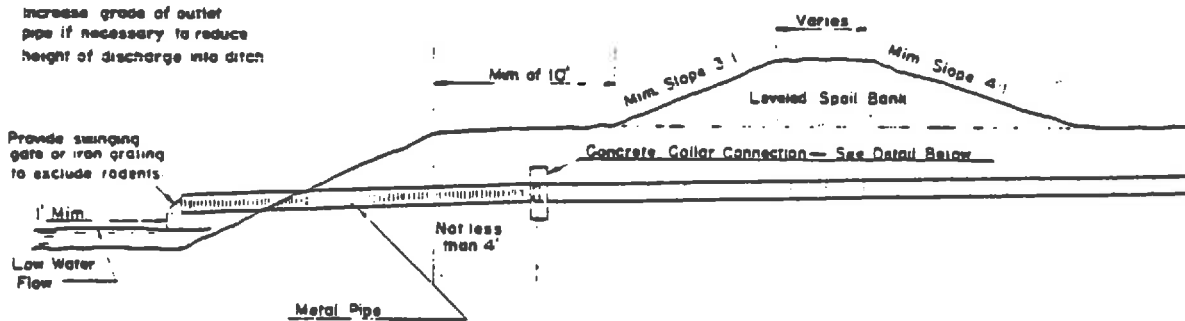

SECTION

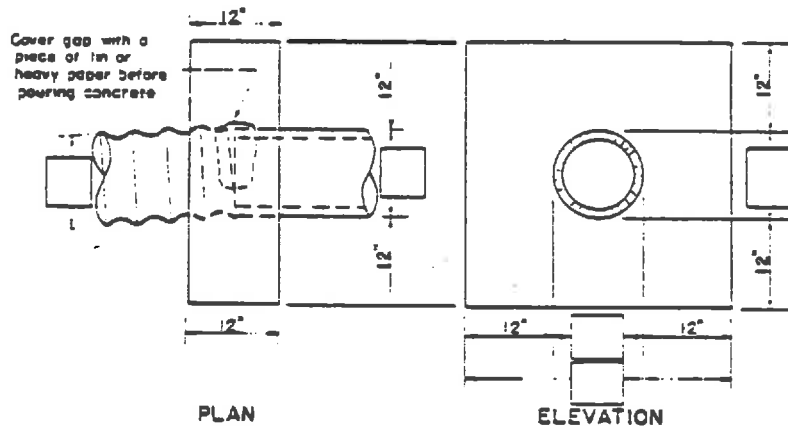

DETAIL-CONCRETE COLLAR

NOTE:

Rigid metal pipe either smooth or corrugated may be used.

If metal pipe is placed on a steeper slope than tile, same size may be used. Use pipe 2" larger than tile if on same slope.

If floating debris is a problem the metal pipe should be placed at approx. 30 degree angle facing downstream instead of as shown.

FIGURE 6-59

Metal Pipe Outlet and Concrete Collar

(USDA-SCS-FL)

- 3) Where floating debris may damage the outlet pipe, the outlet shall be recessed to the extent that the cantilevered portion of the pipe will be protected from the current in the ditch.
- 4) Headwalls which are used for tile outlets shall be adequate in strength and design to avoid washouts and other failures.

Watertight conduit strong enough to withstand the loads upon it shall be used where subsurface drains cross under irrigation canals or other ditches. Conduits under roadways shall be designed to withstand the expected loads. Shallow drains through depressional areas and near outlets shall be protected against hazards of maintenance equipment.

Junction boxes shall be used where more than two main lines join.

Where surface water is to be admitted to drains, inlets shall be designed to exclude debris and prevent sediment from entering the conduit. Drain lines flowing under pressure shall be designed to withstand the resulting pressures and velocity of flow. Auxiliary surface waterways shall be used where feasible.

Headwalls

Headwalls shall be constructed on compact foundation and shall be of long lasting, durable materials such as steel piling, reinforced concrete, concrete block and sand cement riprap. The structures shall be designed to safely withstand expected loads.

Structure Capacity

Structures installed in tile lines must not unduly impede the flow of water in the system. They shall have a capacity no less than that of the line or lines feeding into or through them.

Where the tile system will carry surface waterflow, surface water inlets shall have a capacity no more than that required to provide the maximum allowable design flow in the tile line or lines.

Size of Structures

Junction boxes, manholes, catch basins, and sand traps shall be accessible for maintenance. A clear opening of not less than 2 feet shall be provided in either circular or rectangular structures.

Velocities in Structures

The tile system shall be protected against turbulence created near outlets, surface inlets, or similar structures. Continuous or closed-joint pipe shall

be used in tile lines adjoining the structure where excessive velocities will occur.

Screens and Trash Racks

Surface water inlet structures shall be equipped with screens, trash racks, or gratings to exclude debris.

Junction Boxes

Junction boxes shall be installed where more than two mains join, or where two mains join at different elevations.

Vents

Vents will be located at changes in grade, sharp changes in direction and at intervals along tile lines as needed. They shall be constructed as a tee with the riser pipe extending to ground surface or above. The riser pipe shall not be less than 4 inches in diameter. Each riser pipe shall be provided with a wire mesh or grating cover to prevent trash from entering the lines.

Maintenance of Filter and Underdrain Facilities

An underdrain filter system of adequate design and proper installation, using good material, still requires maintenance to keep it operating. Inspection of the drains, especially after heavy rains, should be made to see if they are working and if maintenance is required. Pore spaces in stormwater filters can be expected to seal with time following the beginning of operation. The duration of a filter's effectiveness before the hydraulic capacity is reduced to the point that drawdown requirements can no longer be met will depend on a number of factors including the initial permeability of filter material used, the degree of pretreatment (sedimentation) prior to entering the filtration facility, and the nature of the pollutants being removed.

Preliminary indication show that these systems can function for up to one year with only minor maintenance. However, periodic discing or scrapping the surface layers of the soil may be required following heavy events that carry heavy sediment loads.

Coarse grained systems may require complete replacement of the filter media to restore their function following clogging since pollutants would be expected to further penetrate these systems than their more close-grained counterparts. Most of the particulates will be trapped in the first 2 or 3 inches of the latter while suspended substances can be expected to penetrate up to a foot or more into the coarse-grained filter. Semi-annual restoration

efforts are likely to involve complete removal and cleaning and or replacement of the top 12 inches or more of the filter material. While major maintenance of this type may not have to be done as often, when it is required, the operation will involve a significant amount of labor and material. Heavy machinery may be needed if the facility is large and care will be needed to prevent damage to the underdrain pipes. There may be some problems associated with the ability of these more coarse-grained, evenly graded materials to support machinery needed to perform maintenance activities, such as scrapping without getting equipment stuck and/or damaging the filter bed.

Common causes of subsurface drainage system failures include the following:

- 1) Drains installed with insufficient capacity.
- 2) Drains placed too shallow and lack of auxiliary structures necessary for the installation.
- 3) Drains of insufficient strength or lacking in other qualities necessary for the installation.
- 4) Poor construction resulting in such inadequacies as too wide or too small a joint spacing, improper bedding, poor grade and alignment and improper backfilling.
- 5) Failure due to mineral deposits such as iron oxide. These deposits do not seriously affect the operation of the drain unless the perforations or joints become sealed. Usually indications of deposits may be observed at the outlets, junction boxes and inspection holes.

Hydraulic Cleaning - High pressure hydraulic nozzles have been used with success to clean tile drains in Florida that have evidence of iron oxide.

Silt and Vegetation - One of the most common maintenance problems that we have with tile drains in Florida is to get landowners to keep the outlets free of silt and vegetation where they empty into open ditches. The outlet end of the system must be kept clean if the maximum benefits from the tile are to be obtained. Sediment and fast growing aquatic vegetation might cause the outlets to become entirely plugged within one year after installation, consequently frequent inspections must be made.

Rodent Guards - Landowners often do not maintain the rodent guards. These appurtenances are sometimes removed, become rusted or plugged, and may never be replaced. These actions invite damage that can lead to the failure of the entire system. The outlet must be inspected periodically to make sure that it is clear, and that these guards are in place and functional.

Trees - If trees near the drain are not removed at the time of construction, the tile may become plugged by roots. If it is found that the tile line is not functioning and the outlet is open, the lines should be checked near trees.

Auxiliary Structures - The life and value of a tile system many times depends on the repair of auxiliary structures. These structures are to protect the tile system as well as to aid in determining when maintenance is needed. If they are not maintained, the value of the installation will decrease. Regular inspection is required.

As-Built Plans - Upon completing a subsurface drainage installation and after all checks and inspection have been made, a set of "As-Built" plans, showing location, depths and sizes of all drains should be preserved and made available to those that will be maintaining the system.